

Axial needle roller and cage assemblies
Axial bearing washers
Axial needle roller bearings

Product overview **Axial needle roller and cage assemblies, washers, axial needle roller bearings**

Axial needle roller and cage assemblies

AXK



Axial bearing washers

AS

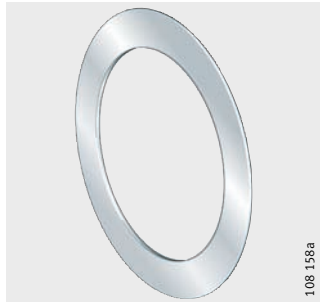

Axial needle roller bearings With centring spigot

AXW

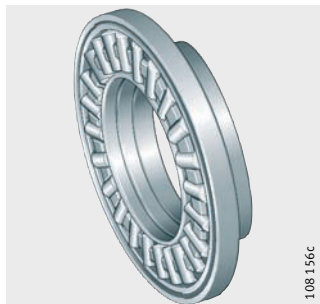

Other products

AX



Axial needle roller and cage assemblies Axial bearing washers

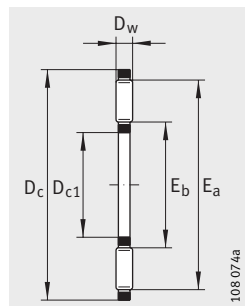

AXK

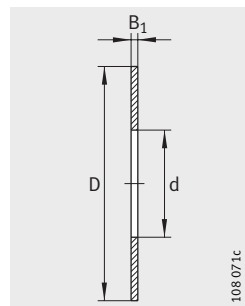

AS

Dimension table - Dimensions in mm

Axial needle roller and cage assemblies		Axial bearing washers		Dimensions			
Designation	Mass m ≈g	Designation	Mass m ≈g	D _{c1} /d	D _c /D	D _w	B ₁
AXK0414-TV	0,7	AS0414	1	4	14	2	1
AXK0515-TV	0,8	AS0515	1	5	15	2	1
AXK0619-TV	1	AS0619	2	6	19	2	1
AXK0821-TV	2	AS0821	2	8	21	2	1
AXK1024	3	AS1024	3	10	24	2	1
AXK1226	3	AS1226	3	12	26	2	1
AXK1528	4	AS1528	3	15	28	2	1
AXK1730	4	AS1730	4	17	30	2	1
AXK2035	5	AS2035	5	20	35	2	1
AXK2542	7	AS2542	7	25	42	2	1
AXK3047	8	AS3047	8	30	47	2	1
AXK3552	10	AS3552	9	35	52	2	1
AXK4060	16	AS4060	12	40	60	3	1
AXK4565	18	AS4565	13	45	65	3	1
AXK5070	20	AS5070	14	50	70	3	1
AXK5578	28	AS5578	18	55	78	3	1
AXK6085	33	AS6085	22	60	85	3	1
AXK6590	35	AS6590	24	65	90	3	1
AXK7095	60	AS7095	25	70	95	4	1
AXK75100	61	AS75100	27	75	100	4	1
AXK80105	63	AS80105	28	80	105	4	1
AXK85110	67	AS85110	29	85	110	4	1
AXK90120	86	AS90120	39	90	120	4	1
AXK100135	104	AS100135	50	100	135	4	1
AXK110145	122	AS110145	55	110	145	4	1
AXK120155	131	AS120155	59	120	155	4	1
AXK130170	205	AS130170	65	130	170	5	1
AXK140180	219	AS140180	79	140	180	5	1
AXK150190	232	AS150190	84	150	190	5	1
AXK160200	246	AS160200	89	160	200	5	1



Raceway dimensions		Basic load ratings		Fatigue limit load	Limiting speed	Reference speed
E _b	E _a	dyn. C _a N	stat. C _{0a} N	C _{ua} N	n _G min ⁻¹	n _B min ⁻¹
5	13	4 400	8 000	940	21 500	14 900
6	14	4 750	9 200	1 070	20 600	13 000
7	18	6 800	15 500	1 580	18 900	10 800
9	20	7 800	19 400	1 970	17 800	8 800
12	23	9 200	25 500	2 500	16 900	7 400
14	25	9 900	29 000	2 850	15 200	6 500
17	27	11 300	36 000	3 600	13 200	5 100
19	29	11 900	39 500	3 950	12 100	4 600
22	34	13 100	46 500	4 750	10 500	4 350
29	41	14 700	58 000	5 900	8 400	3 850
34	46	16 300	70 000	7 100	7 300	3 200
39	51	17 800	81 000	8 300	6 500	2 800
45	58	28 000	114 000	11 800	5 600	2 440
50	63	30 000	128 000	13 300	5 100	2 170
55	68	32 000	143 000	14 800	4 700	1 950
60	76	38 000	186 000	20 300	4 250	1 780
65	83	44 500	234 000	26 500	3 900	1 590
70	88	46 500	255 000	28 500	3 650	1 470
74	93	54 000	255 000	26 500	3 450	1 430
79	98	55 000	265 000	28 000	3 250	1 350
84	103	56 000	280 000	29 500	3 100	1 280
89	108	58 000	290 000	30 500	2 950	1 220
94	118	73 000	405 000	44 500	2 700	1 120
105	133	91 000	560 000	58 000	2 420	980
115	143	97 000	620 000	63 000	2 230	890
125	153	102 000	680 000	68 000	2 070	810
136	167	133 000	840 000	75 000	1 900	760
146	177	138 000	900 000	79 000	1 780	710
156	187	143 000	960 000	82 000	1 680	660
166	197	148 000	1 020 000	86 000	1 590	620

Axial needle roller bearings

With centring spigot

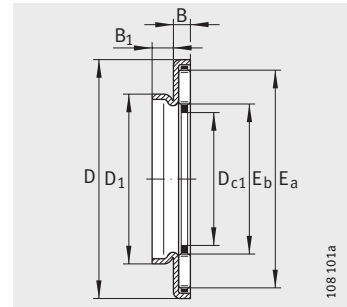

AXW

Dimension table - Dimensions in mm

Designation	Mass m ≈g	Dimensions					Raceway dimensions		Basic load ratings		Fatigue limit load C _{ua} N	Limiting speed n _G min ⁻¹	Reference speed n _B min ⁻¹
		D _{c1}	D ₁	D	B	B ₁	E _b	E _a	dyn. C _a N	stat. C _{0a} N			
AXW10	8,3	10	14	27	3,2	3	12	23	9 200	25 500	2 500	16 900	8 300
AXW12	9,1	12	16	29	3,2	3	14	25	9 900	29 000	2 850	15 200	7 300
AXW15	10	15	21	31	3,2	3,5	17	27	11 300	36 000	3 600	13 200	5 800
AXW17	11	17	23	33	3,2	3,5	19	29	11 900	39 500	3 950	12 100	5 300
AXW20	14	20	26	38	3,2	3,5	22	34	13 100	46 500	4 750	10 500	4 900
AXW25	20	25	32	45	3,2	4	29	41	14 700	58 000	5 900	8 400	4 250
AXW30	22	30	37	50	3,2	4	34	46	16 300	70 000	7 100	7 300	3 600
AXW35	27	35	42	55	3,2	4	39	51	17 800	81 000	8 300	6 500	3 100
AXW40	39	40	47	63	4,2	4	45	58	28 000	114 000	11 800	5 600	2 700
AXW45	43	45	52	68	4,2	4	50	63	30 000	128 000	13 300	5 100	2 400
AXW50	49	50	58	73	4,2	4,5	55	68	32 000	143 000	14 800	4 700	2 160

¹⁾ Dimensions for axial bearing washers AS, for drawn cup needle roller bearings with open ends, drawn cup needle roller bearings with closed end and needle roller bearings: see corresponding product section.

Combination with radial needle roller bearings

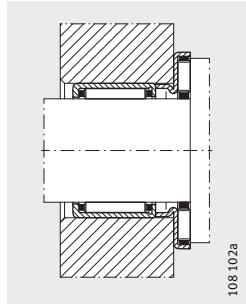

AXW with HK

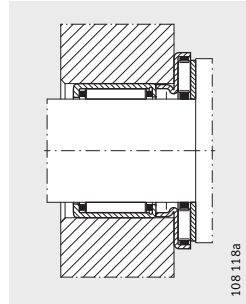

AXW with AS and HK

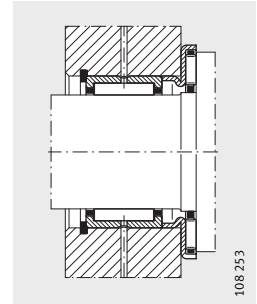

AXW with NK, NKS, RNA49, RNA69



Combination with drawn cup needle roller bearings with open ends, drawn cup needle roller bearings with closed end and with needle roller bearings

Designation

AS	HK	HK.-RS	BK	NK, NKS, RNA49, RNA69 Needle roller bearings ¹⁾	NKI, NKIS, NA49, NA69 Needle roller bearings ¹⁾
AS1024 –	HK1010, HK1012 HK1015	– –	BK1010, BK1012 BK1015	NK7/10-TV NK7/12-TV	– –
AS1226 –	HK1210 –	– –	BK1210 –	NK9/12-TV NK9/16-TV	NKI6/12-TV NKI6/16-TV
AS1528 –	HK1512, HK1516 HK1522-ZW	HK1514-RS –	BK1512, BK1516 –	– –	– –
AS1730	HK1712	–	–	NK15/16, NK15/20	–
AS2035 – –	HK2012, HK2016 HK2020 HK2030-ZW	HK2018-RS – –	BK2016 BK2020 –	NK18/16, NK18/20 – –	– – –
AS2542 – –	HK2512, HK2516 HK2520, HK2526 HK2538-ZW	HK2518-RS – –	– BK2520, BK2526 BK2538-ZW	NK24/16, NK24/20 NKS20 –	NKI20/16 NKI20/20 –
AS3047 – –	HK3012, HK3016 HK3020, HK3026 HK3038-ZW	HK3018-RS – –	BK3012, BK3016 BK3020, BK3026 BK3038-ZW	NK28/20, NK28/30 NKS 24 RNA4904, RNA6904	NA4904 NA6904 –
AS3552 – –	HK3512, HK3516 HK3520 –	HK3518-RS – –	– BK3520 –	NK32/20-TV, NK32/30 NKS28 RNA4905, RNA6905	NKIS20, NA4905 NA6905 NKI28/20-TV, NKI28/30
AS4060 – – –	HK4012, HK4016 HK4020 – –	HK4018-RS – – –	– BK4020 – –	NK37/20, NK37/30 NKS32 RNA4906, RNA6906 –	NKIS25, NA4906 NA6906 NKI32/20 NKI32/30
AS4565 – –	HK4516, HK4520 – –	HK4518-RS – –	BK4520 – –	NK42/20, NK42/30 NKS37 RNA49/32, RNA69/32-ZW	NKIS30 NA49/32 NA69/32-ZW
AS5070	HK5020, HK5025	HK5022-RS	–	NKS43	NKIS35