

your global specialist

Industrial sector

Driving with Klüber Lubrication.

Speciality lubricants for the automotive industry





Klüber Lubrication: More than speciality lubricants	3
Body & Exterior	6
Interior	10
Chassis	14
Powertrain	18
Our products and their main characteristics	22
Notes	26
Imprint	27

Klüber Lubrication: More than speciality lubricants

New developments in the automotive industry are made quickly; the brand-new developments of today being the basic equipment of tomorrow. The car of the future is subject to rising demands: it is to be greener, safer, and more comfortable. For many new developments and their on-board operation, one component plays a key role: the speciality lubricant.

As a manufacturer of vehicles and components, you trust the lubricant to reliably fulfil your and your customers' requirements during the lifetime of the car. Invisible for the passengers, the lubricant makes a major contribution to your success; high-quality speciality lubricants can help you reduce the risk of malfunctions and recalls.

Klüber Lubrication knows exactly what the special requirements of the automotive industry are. We are in constant dialogue with car manufacturers and their suppliers. Our experts are always at your side as consultants and development partners, whether you are adapting, redesigning or newly developing either parts, components or complete systems.

We offer personal solutions designed to meet your needs and requirements: some of them are products that have been successfully used in the field for many years; others are especially developed lubricants tested thoroughly on rigs adjusted for your specific requirements.

Yet, merely to offer suitable products is not sufficient to meet the total scope of your needs. We strive to be your preferred supplier of speciality lubricants. We are wherever you need us - our specialists are at your side worldwide. Safe, quick, flexible and reliable solutions is what Klüber Lubrication stands for.

Our certifications

Klüber Lubrication Location		ISO 9001	ISO/TS 16949	ISO 14001
Europe	Austria	✓	✓	✓
	Belgium	✓	✓	✓
	Germany	✓	✓	✓
	Italy	✓	✓	✓
	Spain	✓	✓	✓*
	Turkey	✓	✓	✓
America	Argentina	✓	✓	✓
	Brasil	✓	✓	✓
	Mexico	✓	✓	✓
	USA	✓	✓	✓
Asia	China	✓	✓	✓
	India	✓	✓	✓
	Japan (NOK)	✓	✓	✓
	Korea	✓	✓	✓

*additional certification according to EMAS



Klüber Lubrication: More than speciality lubricants

Field-tested quality

Our products have proven their value in the automotive industry for decades, well confirmed by our customers with a multitude of approvals and specifications.

The right product for every requirement

The approx. 250 friction points in a car all have very different tribological requirements. Klüber Lubrication offers you the right lubricant for each. Should we not have it on our shelves yet, we will develop it together with you. Our technical advisers are happy to support you in finding the best product for your ideas.

Development partner and consultant

We participate in many working groups and committees, e.g. the German Automotive Industry Association (VDA), the German Society for Tribology, the European Lubricating Grease Institute (ELGI), the REACH Implementation Project and the German Association of the Chemical Industry. Klüber Lubrication takes part in decision-making and development processes affecting lubricants for the automotive industry at an early stage, ensuring that you have a lubrication partner that understands the demands being placed upon the lubricants you need. Our certifications include ISO TS 16949, ISO 9001, ISO 14001 and EMAS, and testify to the quality of our products.

A test bay that is unrivalled worldwide

We develop and test our automotive speciality lubricants based on the specific requirements of your industry. Our unique test bay offers more than 100 test rigs, some of which we developed

ourselves for particular testing purposes. In our development activities, we attach great importance to close cooperation with automobile manufacturers and suppliers. We adjust the test rigs to your requirements where needed. After all, we know how important it is that the lubricant meets, or even exceeds, your requirements already during testing.

Global presence

We are where you are. Our specialists are there to support you, wherever you need them. We help you select the right product or develop a solution tailored to your requirements.

“Made by Klüber Lubrication” stands for a consistent quality level worldwide. We offer you products that are all made to the same high quality, no matter whether produced in Asia, Europe or the Americas.

Your partner for speciality lubricants in the automotive industry

We consider ourselves your partner in all tribological questions. We offer more than excellent products and high competence:

- Quick and flexible handling of your enquiry
- Competent technical and commercial consulting
- Reliable information
- Added value: more than just a product
- Local presence: we are where you are

Test us!

The Klüber Lubrication Performance Spectrum

Speciality lubricants and added value for our customers

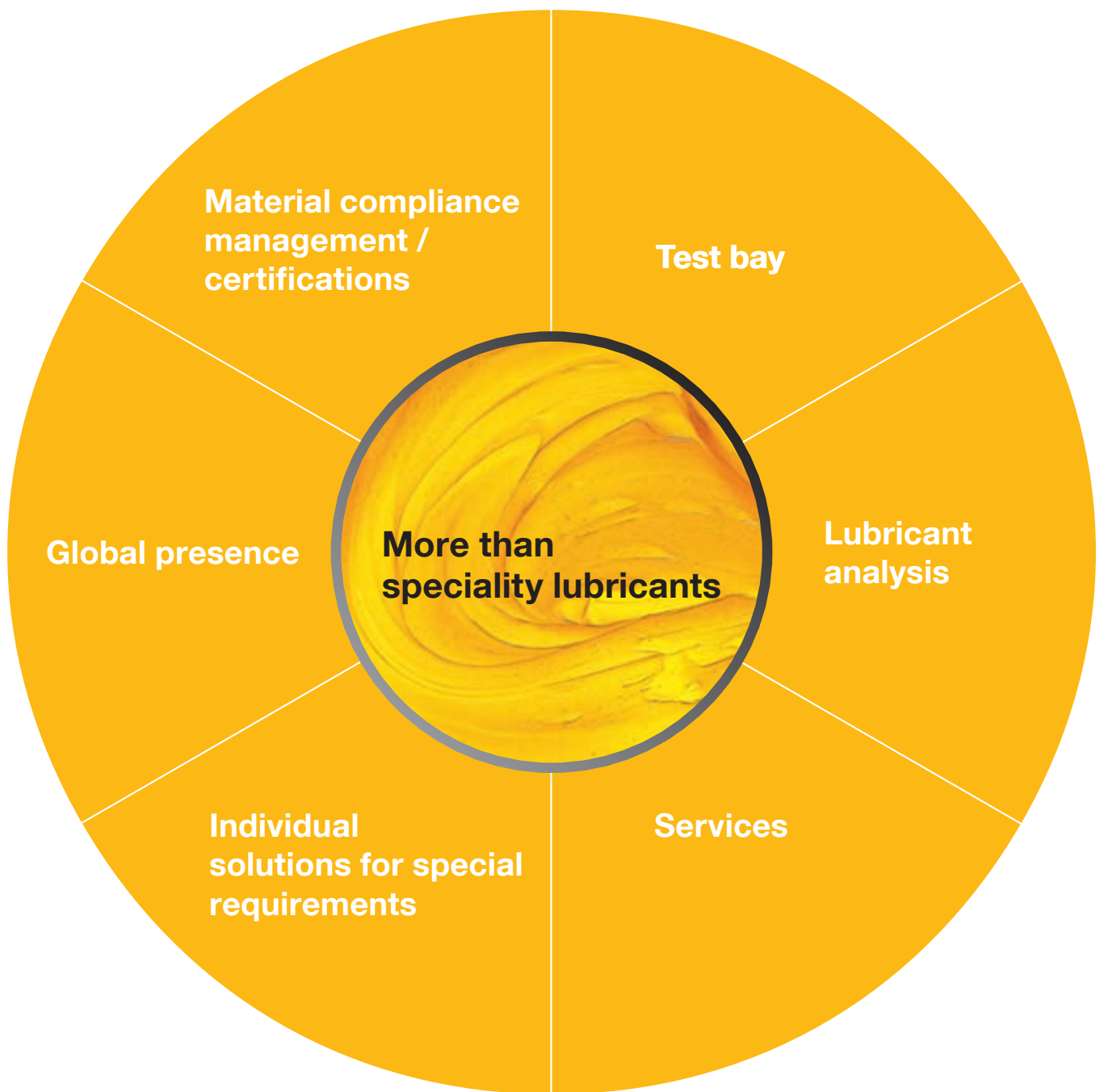

Body & Exterior

Lubricants for car bodies and exterior areas must be highly effective within specified temperature ranges and withstand salt, water and dust for many years. Our lubricants ensure smooth operation of sun roofs, window mechanisms, etc. for their entire lifetime.

Sliding roof - guide rails
Klüberplex RA 41-151
Wide temperature range
and noise optimisation

Windshield wiper blades
Klüberplus S02-004
Water-miscible dispersion
reducing stick-slip

Wiper motor planetary gear
ISOFLEX TOPAS L 32
High performance at low
temperatures

Adaptive frontlight and washer system
BARRIERTA KL 092
Chemical resistance and service
temperatures > 200 °C

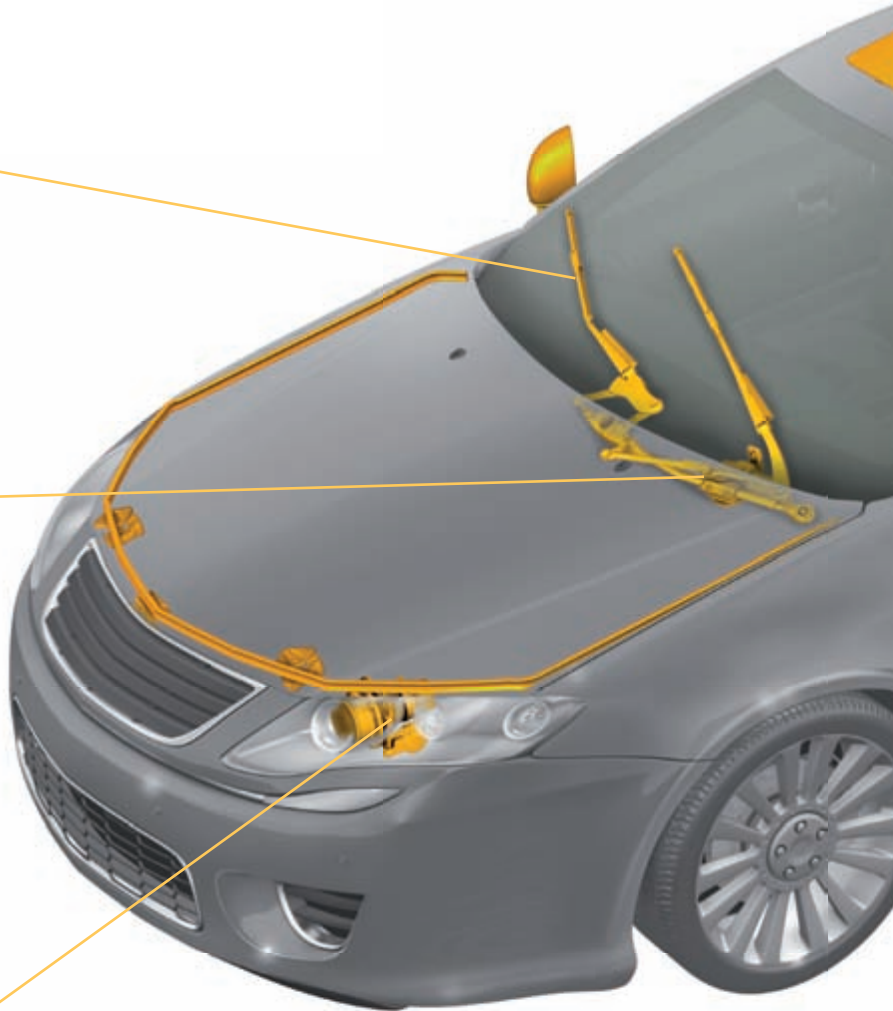

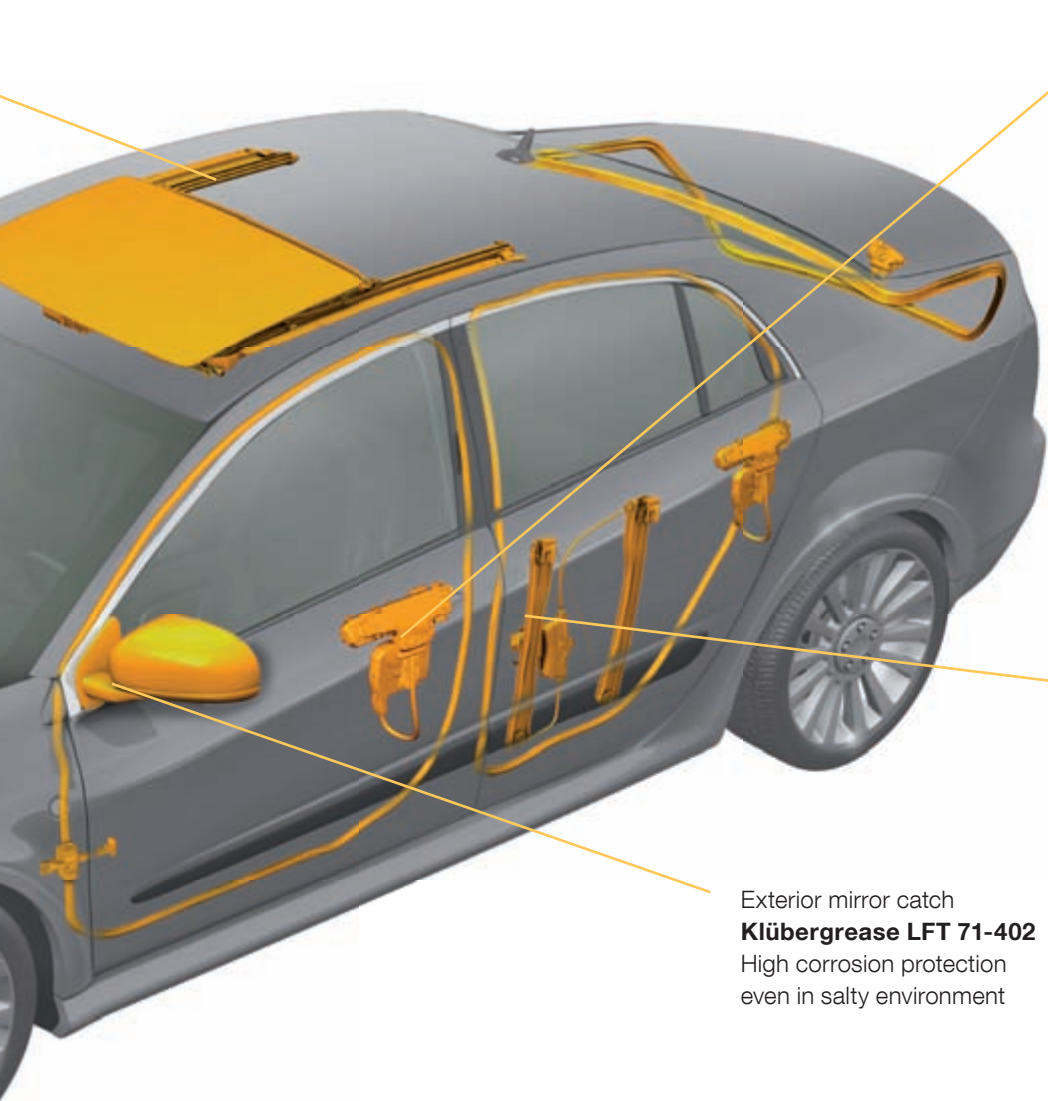

Central locking system
ISOFLEX TOPAS L 32 N
 Low-temperature grease with
 UV indicator for dosing detection

Window lifter guide rails
Klübersynth LR 44-21
 Low-temperature grease
 providing resistance against dust

Exterior mirror catch
Klübergrease LFT 71-402
 High corrosion protection
 even in salty environment

Our customers

Audi, BMW, Bosch, Brose, Daimler, Edscha, Ford, General Motors, Grupo Antolin, Huf, Hyundai/Kia, Igarashi, IMS Gear, Inalfa, Inteva, Johnson Electric, Kiekert, Lames, Magna, MGI Coutier, Mitsuba, Nuova SME, PHA, Valeo, Volkswagen, Webasto, Witte/Strattec

Product approvals

Chrysler MS 9958, Daimler DBL 6827.40, Ford WSD-M1C234-A2, Ford WSD-M1C238-A, Ford WSD-M1C244-A, Ford ESF-M1C43-A2, Ford WSB-M1C160-D2, Ford WSD-M1C234-A, HKMC MS511-39, Opel B 0400571, Opel B 0400852, Opel B 0400858, Opel B 0401122, Opel B 0401138, Porsche 999.917.544.00, Porsche 999.917.790.00, PSA B 71 3841, Toyota TSK2522G, VW-TL 52141, VW-TL 52147, VW-TL 52150, VW-TL 751, VW-TL 767 X, VW-TL 778 A, VW-TL 778 B

Please note that the a.m. information is only a small extract from our range of products and applications with no claim of completeness

Body & Exterior	Component requirements	Lube points	lifetime lubrication	compatibility with polymers	resistance to water & detergents	dust & dirt capacity	wear protection & load carrying capacities	corrosion protection	low temperature performance	freeze release
Windshield Wiper & Wash Water System	Wiper Motor - Sinter Bearings		xx				x	xx	xx	
	Wiper Motor - Gear System		xx	x			x	x	xx	
	Wiper Linkage		x		x		xx	x	x	
	Wash Water Pump Seals		x	xx	xx				x	
	Head Light Telescope Washer - Seal		x	xx	xx	xx			x	
	Wiper Blades									
Doors & Lock Systems	Door handle		x	x	xx	xx	x	x		
	Tail Gate Lifter		xx				xx		x	
	Latch / Pawls		x	x	x	x	x	x	xx	
	Lock Mechanisms		x	x	x	x		x	xx	
	Lock Cylinder				xx	x		x	x	xx
	Catch			x	x	xx	xx	x	x	
	Sliding Door - Spindle Drive		xx	x			xx	x	x	
Window Lifters	Sliding Door - Guide		x		x	xx	x		x	
	Cable Drive - Guides		x	x	xx	xx			xx	
	Cable Drive - Rollers		x	x	x	x	x	x	xx	
	Cross Arm - Guides		x	x	x	xx	xx	x	xx	
	Cross Arm - Tooth Segment		x		x	x	xx	x	x	
	Manual WL - Clutch		x			x	xx	x		
Sliding Roofs	Gearmotors - Worm Gear		xx	x			x	x	xx	
	Kinematics / Mechanics		x							
	Manual Roof - Lock System		xx			x		x		
	Guide Rails			xx	xx	xx			xx	
	Flocked Flex Cables		x						x	x
	Elastomer Profiles - flocked / non-flocked			xx	xx	x				
	Gearmotors - Worm Gear		xx	x			x	x	xx	
Exterior Mirrors	Roller Shade - Axle & Guides		x	xx		x			x	
	Catch		x		xx	xx	x	xx	x	
Front Lights	Gearmotors - Plastic Gear		xx	x	x	x	x	x	xx	
	AFS Actuator - Gear		xx	x	x				xx	
	AFS Actuator - Linkage			x	x	x				
Bonded Coatings for Elastomer	AFS Actuator - Bearings		xx		x				xx	
	Weatherstrips		xx							
	Wiper Blades									
	Flocked Profiles		x							xx

	low friction & high efficiency	low break away & running torques	anti squeak & anti stick-slip	good adhesion	wide temperature range	damping of haptics	self locking	Products
	x	xx						CONSTANT GLY 2100, CONSTANT OY K Series, MIKROZELLA Series
	xx	xx						ISOFLEX TOPAS L 32 / L 32 N, Klübersynth LF 44-22, POLYLUB GLY 501
								Klüberlub EM 41-142
	x	x		x				Klübertop TP 36-1300 A/B
	x	xx	x	x				BARRIERTA KL 092, BARRIERTA L 55/2, SYNTHESO GLEP 1
	x		xx	xx				Klüberflex 200-0 and Modules, Klüberplus S 02-004
				x		x		CENTOPLEX 24 DL / 1 DL
		x	x					Klübersynth LI 44-22, POLYLUB GLY 151
	xx	xx				x		ISOFLEX TOPAS L 32 / L 32 N, Klübertop TM 06-111
	xx	xx		x		x		ISOFLEX TOPAS L 32 / L 32 N, Klübersynth LF 44-22, Klübersynth LI 44-22, Klübersynth RA 44-702, SYNTHESO GLEP 1
								Klüberalfa IR 83-22
				xx		x		Klübersynth HB 74-401, STABUTHERM GH 461
	xx	x						Klübersynth HIP 84-401
				xx				Klübersynth HB 74-401, STABUTHERM GH 461
	xx	xx	xx	xx				ISOFLEX TOPAS L 32 / L 32 N, Klübersynth LR 44-21
	xx	xx	xx					ISOFLEX TOPAS L 32 / L 32 N
	xx	xx	xx			x		ISOFLEX TOPAS L 32 / L 32 N, Klübersynth RA 44-702, POLYLUB GLY 151
				xx				CENTOPLEX 24 DL / 1 DL, Klüberlub EM 41-142, Klüberlub LM 41-102
				x		x	x	Klüberlub EM 41-142, Klüberlub LM 41-102
	xx	xx					xx	ISOFLEX TOPAS L 32 / L 32 N, Klüberlub LM 41-102, Klüberlub LM 41-32 N, Klübersynth LF 44-22, POLYLUB GLY 151
					x			ISOFLEX TOPAS L 32 / L 32 N, Klübersynth LF 44-22, Klübersynth P 84-52 G, Klübertemp GR M30, POLYLUB GLY 501, POLYLUB GLY 801
				x		x		ISOFLEX TOPAS L 32 / L 32 N, Klüberlub LM 41-32 N, Klübersynth LF 44-22
	x	xx	xx	xx				ISOFLEX TOPAS L 32 / L 32 N, Klübersynth LF 44-22, Klübersynth P 84-52 G, Klüberplex RA 41-151, Klübertemp GR M30, POLYLUB GLY 151
	xx	x	xx					Klüber Summit HySyn FG 68, Klüberoil 4 UH1-150 N/...-450 N
			xx	xx				Klüberalfa DH 3-230 N, Klübertemp GR M07, Klübertemp GR M30, Klübertemp RHB 83-202, Klübertop TP 18-810 N
	xx	xx			x			ISOFLEX TOPAS L 32 / L 32 N, Klübersynth LF 44-22, Klübersynth LI 44-22
	x		xx			x		ISOFLEX TOPAS L 32 / L 32 N, Klübersynth MR 96-31, Klübertemp GR M07, Klübertemp RHB 83-202, POLYLUB GLY 801
				x		x		DUOTEMPI PMY 45, Klübergrease LFT 71-402
	xx	xx		x			x	CENTOPLEX 24 DL / 1 DL, ISOFLEX TOPAS L 32 / L 32 N, ISOFLEX TOPAS NB 5051, Klübersynth LF 44-22
	x	xx			xx			BARRIERTA KL 092, Klübertemp GR M07, Klübertemp GR M30
			xx					BARRIERTA L 55/2, POLYLUB GLY 801, SYNTHESO GLEP 1
	x	xx			xx			BARRIERTA KL 092, Klübertemp GR M07
			xx	xx				Klübertop TP 22-1310 A/B
	x		xx	xx				Klüberflex 200-0 and Modules, Klüberplus S 02-004
			xx	xx				Klübertop TP 18-810 N

Interior

Noise damping and top-quality haptics are in focus when it comes to the interior, where e.g. regulators and knobs must move smoothly. Moreover, the interior should be free of unpleasant odours to create a first-rate impression. Our range of odour-optimised damping greases is carefully tuned to meet such requirements.

Central armrest
OPTAPLUS AO 35
Prevention of squeaks, rattles and other NVH problems

Glove compartment lock mechanism
POLYLUB GLY 801
Compatible with many materials;
for good haptics

HVAC flaps
Klüberbeta RM 47-102
Very low fogging tendency

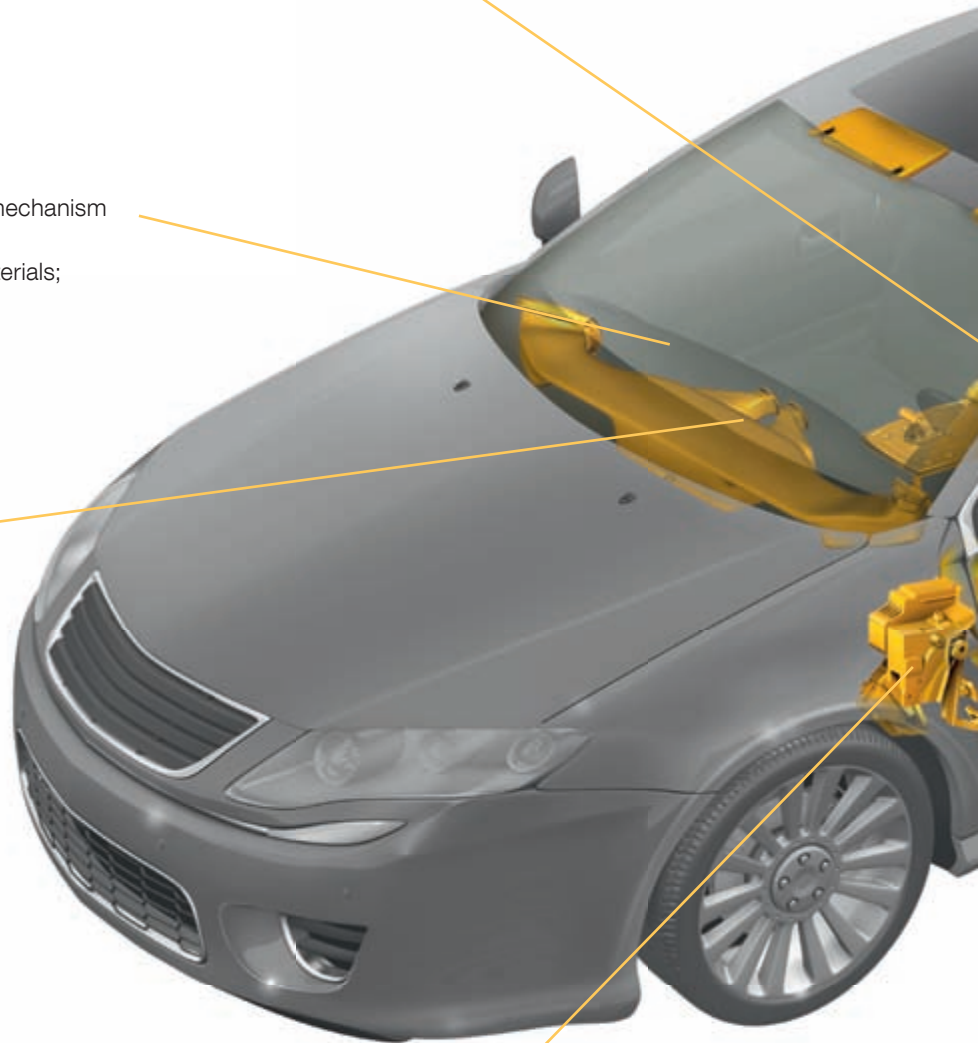

Pedal box
POLYLUB GLY 151
Smooth operation and noise prevention

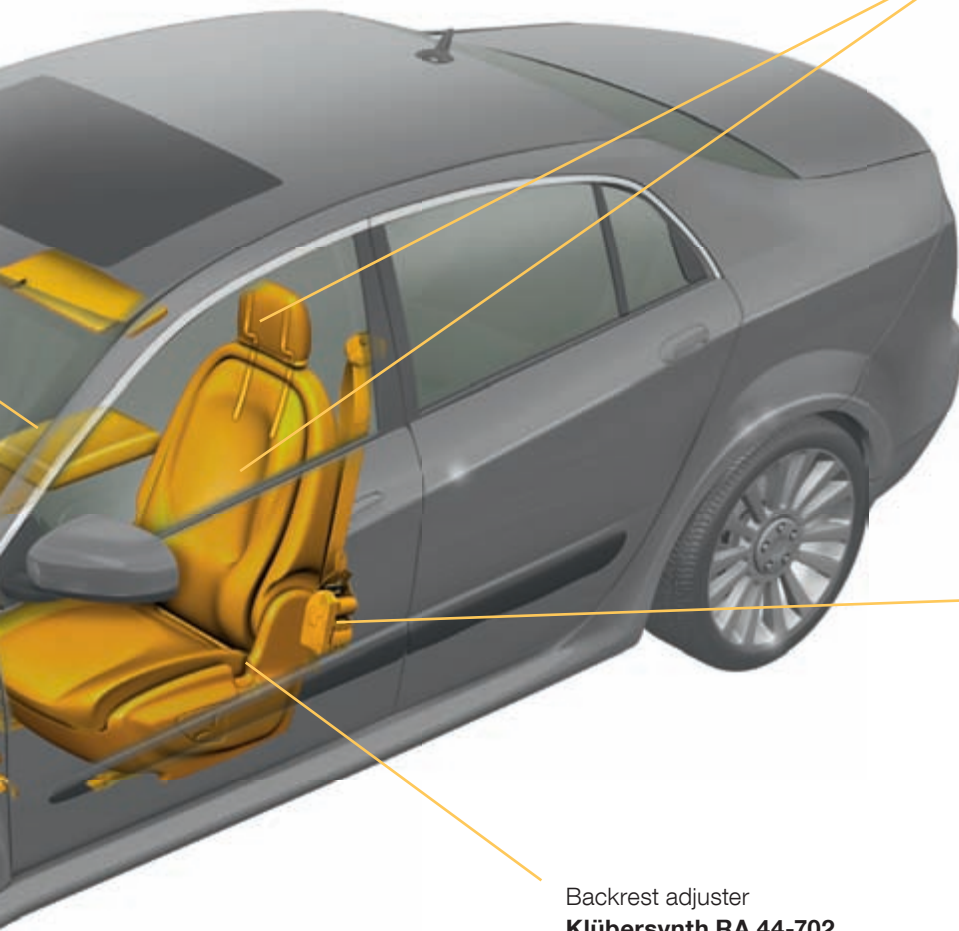

Lumbar support and crash-active headrest
Klübersynth LF 44-22
 Low friction values for ease of use and safety

Variable seat belt retractor
Klübersynth LR 44-21
 Lifetime operation of gear motor actuators

Backrest adjuster
Klübersynth RA 44-702
 Damping effect without juddering and slipping

Our customers

Audi, Autoliv, BHTC, BMW, Bosch, Brose, Daimler, DAS, Faurecia, Ficos, Ford, General Motors, Grammer, Hella, Hyundai/Kia, Johnson Controls, Kern-Liebers, Kostal, L&P Automotive, Lear, Magna, Niles Parts, NMB, NSK, Opel, PSA Peugeot Citroën, Schukra, Sitech, TRW, Valeo, Volkswagen

Product approvals

Chrysler MS 9958, Daimler DBL 6827.40, Ford WSB-M1C160-D2, Ford WSD-M1C234-A2, Ford WSD-M1C244-A, Ford WSS-M99C123-A, Opel B 0400858, Opel B 0400882, Opel B 0401122, Opel B 0401138, Porsche 999.917.790.00, Porsche 999.917.791.00, PSA B 71 3841, Toyota TSK2521G, VW-TL 52147, VW-TL 751, VW-TL 778 A, VW-TL 778 B

Please note that the a.m. information is only a small extract from our range of products and applications with no claim of completeness

Interior	Component requirements	Lube points								
		lifetime lubrication	reliability in regard to safety criticality	no impairment of top- & e-coat	suitable for e-contacts	compatibility with polymers	wear protection & load carrying capacities	low temperature performance	low friction & high efficiency	low break away & running torques
Seat Belts	Clock Spring Retractor	xx	xx			x	x	xx		
	Inertia Blockage	x	x					xx	xx	xx
	Vertical Adjustment B-Column	x				x	x			
	B-Pillar Loop	x					xx		xx	
	Seat Belt Server	x				x		xx	x	x
	Variable Tensioner - Gearmotor	xx	xx		x	x	x	xx	xx	xx
	Pyro-Tensioner - Seals	xx	xx			xx				
Switches/Controls	Multifunction Switch	xx			xx	x	x	x	x	
	Adjustment Switch - Mirror / Seat	xx			xx	x		xx		
	HVAC Control Knobs	xx			xx	xx		x		
	HVAC Flaps	x	x			xx	x	x		x
	E-Connectors	xx	x		xx		x	xx	x	
Compartment	Glovebox Mechanisms	x				xx	x	x		
	Sun Visor	x				x	x	x		
	Center Armrest Kinematics	x				x		x		
	Gear Shift - Selector / Cover					xx				
Pedalbox	xx	x			x	x	x			
Seats	Recliner - Manual	xx		x			xx	x		
	Height Adjustment - Manual	xx		x			xx	x		
	Rails / Tracks / Ratchets	x		x			xx	xx		x
	Height Adjustment - Gearmotor	xx				x	x	xx	xx	xx
	Length Adjustment - Spindle	x				x	xx	xx	xx	x
	Lumbar Support - Spindle	xx				x	xx	xx	xx	x
	Anti Whiplash	xx	x							
	Headrest - passive / crash active	x				xx	x			
	Inner Trunk Cover / Load Systems	xx				x	x			
Folding / Sliding Table					x		x			
NVH	Plastic-Plastic Contact Noises					xx				

	anti squeak & anti stick-slip	damping of haptics	self locking	Products
		x		CENTOPLEX CX 3/350, Klübersynth LR 44-21, Klübersynth MR 96-31, UNISILKON GLK 112
				ISOFLEX LDS 18 Special A / A UV, ISOFLEX TOPAS L 32 / L 32 N
	xx	xx		ISOFLEX TOPAS L 32 / L 32 N, Klübersynth LF 44-22, Klübersynth RA 44-702 /-3502, POLYLUB GLY 151
	x			Klüberbtop TP 39-311 A/B
	xx	xx	x	ISOFLEX TOPAS L 32 / L 32 N, Klübersynth LF 44-22, Klübersynth LI 44-22
			x	Klüberlub EM 41-142, Klübersynth LR 44-21
				UNISILKON GLK 112
		xx		Klüberlectric KR 44-22 /-102 /-402, Klübersynth RA 44-702 /-3502
	x	xx		BARRIERTA L 55/2, Klüberlectric KR 44-22 /-102 /-402, Klübersynth LI 44-22, Klübersynth RA 44-702 /-3502
	x	xx		ISOFLEX TOPAS L 32 / L 32 N, Klübersynth LF 44-22, Klübersynth LI 44-22, Klübersynth RA 44-702 /-3502
	xx			Klüberbeta RM 47-102, Klübersynth RA 44-702 /-3502, UNISILKON GLK 112
				Klüberalfa K 83-735, Klüberalfa MR 3 series, Klüberlectric KR 44-22 /-102 /-402, KONTASYNTH BA 100 SPRAY
	xx	xx		BARRIERTA L 55/2, Klübersynth RA 44-702 /-3502, POLYLUB GLY 501, POLYLUB GLY 801
	xx	xx		DUOTEMPI PMY 45, Klübersynth RA 44-702 /-3502, Klüberbtop TP 03-111
	xx	xx		Klübersynth RA 44-702 /-3502, OPTAPLUS AO 35
	xx			Klübersynth LIP 84-42, KONTASYNTH BA 100 SPRAY, POLYLUB GLY 151, POLYLUB GLY 501, POLYLUB GLY 801, UNISILKON GLK 112
	xx	x		Klübersynth RA 44-702 /-3502, POLYLUB GLY 151, POLYLUB GLY 501, POLYLUB GLY 801
	x	x		ISOFLEX TOPAS L 32 / L 32 N, ISOFLEX TOPAS NB 52, Klübersynth RA 44-702 /-3502
	x	x	x	ISOFLEX TOPAS L 32 / L 32 N
	x	x		ISOFLEX TOPAS L 32 / L 32 N, Klüberpaste UH1 84-201, Klübersynth LR 44-21, POLYLUB GLY 151
			xx	ISOFLEX TOPAS L 32 / L 32 N, Klübersynth GE 14-111, Klübersynth LIP 84-42
				ISOFLEX TOPAS L 32 / L 32 N, Klübersynth LF 44-22, Klübersynth LI 44-22, Klübersynth LR 44-21
	x			Klübersynth LF 44-22
				POLYLUB GLY 801
				ISOFLEX TOPAS L 32 / L 32 N, Klüberalfa MR 3 Series, Klüberalfa YM 3-30, Klübersynth LF 44-22, Klüberoil 4 UH 1-32 N
	xx	x		ISOFLEX TOPAS L 32 / L 32 N, Klübersynth RA 44-702 /-3502, POLYLUB GLY 151, POLYLUB GLY 501, POLYLUB GLY 801
	xx	xx		Klübersynth RA 44-702 /-3502
	xx	xx		BARRIERTA L 55/2, Klüberalfa MR 3 Series, Klüberalfa YM 3-30, Klübersynth LIP 84-42, KONTASYNTH BA 100 SPRAY, POLYLUB GLY 501, POLYLUB GLY 801, UNISILKON GLK 112

Chassis

Besides the brakes, steering systems have the highest lubrication requirements in the chassis. We developed lubricants together with well-known steering system manufacturers that ensure a safe driving sensation through low breakaway torque and excellent friction values.

Ball joints
Klübersynth J 44-402
Reduction of breakaway torques

EPS
Klübersynth LE 44-31
Prevention of stick-slip and static friction

Brake booster
SYNTHESO GLEP 1
Long-term sealing effect

Hub unit bearing
Klüberplex BEM 34-132
Longer service life due to wear protection

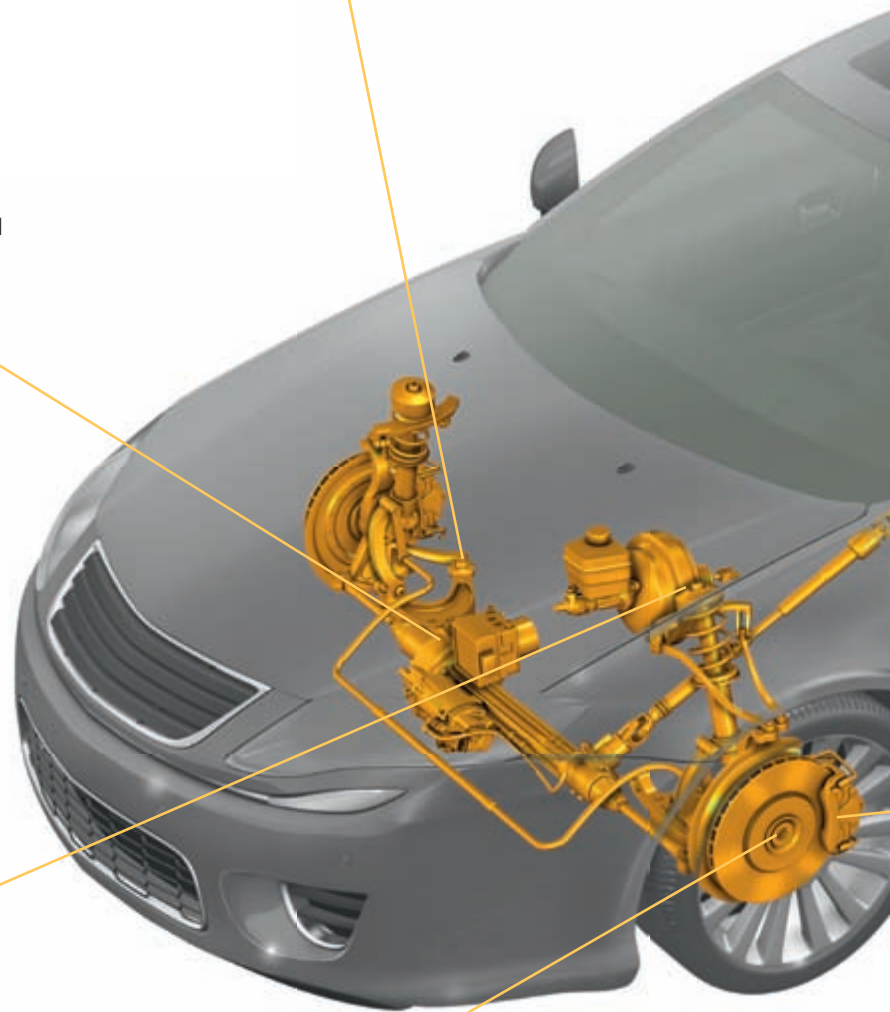



Parking brake bowden cable
UNISILKON GLK 112
 High efficiency and high thermal stability

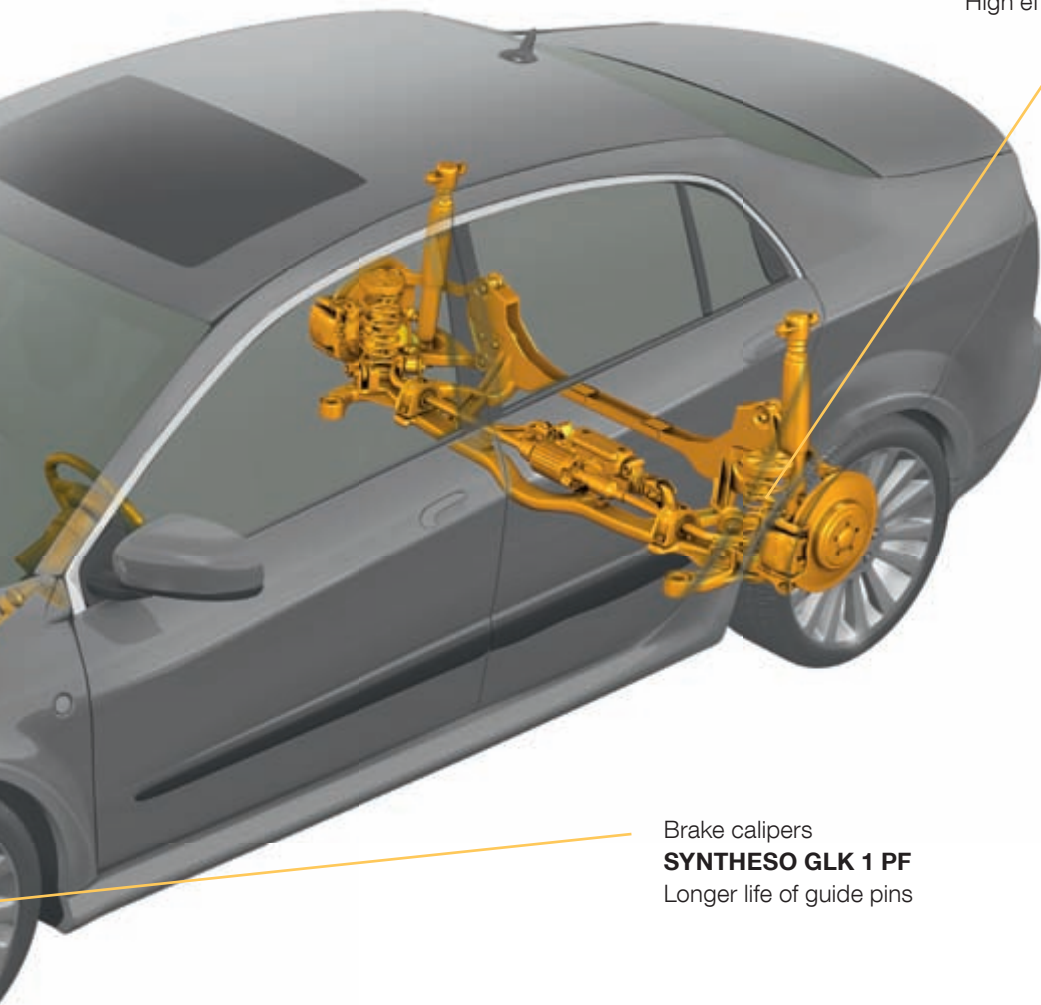

Brake calipers
SYNTHESO GLK 1 PF
 Longer life of guide pins

Our customers

ADVICS (Aisin), Akebono, BMW, Bosch, Brembo, CBI, China Automotive Systems, Continental, Daimler, Dana, Ford, Fujian Jinduo, General Motors, Hyundai/Kia, Iljin, Inauxa, JTEKT, Knorr-Bremse, KYB, Meritor, Musashi, NSK, PSA, Peugeot, Porsche, Raufoss, SEAT, ThyssenKrupp Presta SteerTec, Timken, THK, Visteon, Volkswagen, Wabco, ZF-TRW

Product approvals

Bosch VS 18314-Ft/N 28 FT 1140-002, Brembo D1.04.07.000, Chrysler MS 9708, Continental (ATE) N 5 5315.03, Daimler DBL 6834.00, Delphi 26113298, Ford ESA-M1C194-A, Ford ESF-M99B112-A, Ford WSA-M1C246-A, Ford WSD-M1C234-A2, GM 9986206, Knorr N 503880, Lucas T.S. 2-32-101, Lucas T.S. 2-33-03, Meritor 2297-N-7164, PBR MS 1120, PBR MS 1124, Porsche 999.917.791.00, Toyota TSK2520G, Toyota TSK2522G, Toyota TSK2523G, Toyota TSK2524G, Toyota TSK2525G, TRW 62015002, VW-TL 52112, VW-TL 52150, VW-TL 721, VW-TL 778 B, Wabco JED 294, Wabco JED 785, ZF LMN 304 B, ZF LMN 304 F, ZF LMN 304 K

Please note that the a.m. information is only a small extract from our range of products and applications with no claim of completeness

Chassis	Component requirements	lifetime lubrication	reliability in regard to safety criticality	compatibility with polymers	miscible with brake fluids	EPDM compatibility	resistance to water & detergents	no false brinelling	no fretting / no tribocorrosion		
											Lube points
Brakes	Master Brake Cylinder	xx	xx	xx	xx	xx					
	Slave Cylinder Disc	xx	xx	xx	xx	xx	x				
	Disc Brake Pads					xx	x				
	Disc Brake Caliper - Guide Pins	xx	xx	xx		xx		x	xx		
	Slave Cylinder Drum	xx	xx	xx	xx	xx	x				
	Drum Brake Backing Plate		xx			x	x		xx		
	Drum Brake Adjustment	x			xx	x			xx		
	Park Brake Cable - Linkage	xx	xx	xx		x	x				
	Electric braking systems	xx	xx		x	x					
	ABS Actuator	xx	xx	xx		xx		x			
	Vacuum Brake Booster	xx	xx	xx		xx					
	Air Brake Pneumatic Valves	xx	xx	xx							
	Steering System	Steering Wheel Adjustment - Height / Length	xx	x	x						
		Intermediate Telescope Shaft	xx		x						
Steering Column - U-Joint		xx	xx								
Rack / Pinion / Slide Yoke		xx		x				xx	xx		
Ball Joints - Inner / Outer Tie Rod End		xx	x	xx			xx				
Rear Axle Steering Actuator		xx		x							
EPS Column - Worm Gear		xx		x							
EPS Pinion / DP - Worm Gear		xx		x							
EPS Parallel - Ball Screw		xx						xx	xx		
EPS Parallel - Supporting Bearing		xx						xx	xx		
Steering Angle Sensor		xx	xx								
Axle	Ball Joints - King Pin / Control Arm / Stabilizer	xx	x	xx			xx				
	Hub Unit Bearing	xx		x				xx			
	Roll stabiliser	xx		x							
	Electric roll stabiliser	x									
	Shock Absorber Sealing	x		x			x				
	Strut Bearing	xx					x		x		
	Rubber-Metal Compounds	x		xx		x					

	wear protection & load carrying capacities	corrosion protection	wide temperature range	low friction & high efficiency	low break away & running torques	anti squeak & anti stick-slip	good adhesion	Products
	x	x	xx	x	x	x	xx	Klüberfluid 9 R 100, Klübersynth HLR 46-371, SYNTHESO GLEP 1, SYNTHESO GLK 1
	x	x	xx	x	x	x	xx	Klüberfluid 9 R 100, Klübersynth HLR 46-371, SYNTHESO GLEP 1, SYNTHESO GLK 1
							xx	Klüberpaste 46 MR 401, Klüberpaste HM 96-402
	x	x	xx		x	xx		Klübersynth HLR 46-371, SYNTHESO GLEP 1, SYNTHESO GLK 1, SYNTHESO GLK 1 PF
	x	x	xx	x	x	x	xx	Klüberfluid 9 R 100, Klübersynth HLR 46-371, NONTROP GB 3 G, SYNTHESO GLEP 1, SYNTHESO GLK 1
			x				xx	Klüberpaste 46 MR 401, WOLFRAKOTE TOP PASTE, Klüberpaste HM 96-402
							x	Klüberpaste 46 MR 401, WOLFRAKOTE TOP PASTE, Klüberpaste HM 96-402
			xx	xx		x		Klübersynth LR 44-21, Klübersynth MR 96-31, UNISILKON GLK 112
	x		xx					Klübersynth BR 46-82, Klübersynth BR 46-32 /F, Klübersynth LIR 46-21, BARRIERTA KL 092
	x	x	xx		xx		x	Klübersynth HB 72-52
	x		x	xx	xx	xx		Klübersynth BLR 46-122, SYNTHESO GLEP 1
			x	xx	xx			Klüberbeta RM 47-291, UNISILKON GLK 112, BARRIERTA KM 192
	x			xx	xx	xx		ISOFLEX TOPAS NCA 52, Klübersynth LIP 84-42
	x			xx	xx	xx		ALTEMP Q NB 50, Klübersynth LI 44-22
	xx	x	x		x			Klüberplex BEM 41-141
	xx			x	xx	xx	xx	Klübersynth GE 14-111
	xx	x		xx	xx	xx	xx	Klübergrease LFT 71-402, Klübersynth J 44-402, Klübersynth JIP 84-402
	xx							Klübersynth LE 44-31, Klübersynth LI 44-22, Klübersynth LIP 84-42, Klübersynth BLR 46-122
	xx			xx	xx	xx		Klübersynth LE 14-161, Klübersynth LE 44-31, Klübersynth LI 44-22
	xx		xx	xx	xx	xx		ISOFLEX TOPAS NB 52, Klübersynth LE 44-31
	xx		xx	xx	xx	xx		Klübersynth BME 44-42, Klübersynth BM 44-42
	xx		xx	xx	xx	xx		Klübersynth BM 44-42
			x	xx	xx		x	BARRIERTA KL 092, ISOFLEX TOPAS NCA 52
	xx	x		xx	xx	xx	xx	Klübergrease LFT 71-402, Klübersynth J 44-402, Klübersynth JIP 84-402
		x	x		xx			Klüberplex BEM 34-132 / -131N, Klüberplex BEM 41-132
					xx			SYNTHESO GLEP 1, Klübertop TP 39-111 N A/B
	xx				xx			Klübersynth LP 42-32
				xx	xx	xx	x	Klübersynth RM 14-211, POLYLUB GA 352 P
	xx	xx					x	Klübergrease LFT 71-402, Klüberplex BEM 34-132 / -131N
	x					xx	x	Klüberfluid 9 R 100, QUIETSCH-EX, SYNTHESO GLEP 1, SYNTHESO GLK 1

Powertrain

Lubricants used in vicinity of engine and transmission, as well as lubricants for driveshafts are subject to a wide variety of requirements. Near the engine, temperatures can reach more than 200 °C, while aggressive degradation products accumulate in intake and exhaust systems. We help you overcome these challenges, for example with high-temperature and blow-by resistant speciality lubricants.

Variable intake manifolds.
Klüber Noxlub KF 1920
Reliable lubrication even within blow-by

Electronic waste gate
Klübersynth BR 46-82
Resistant to waste heat

Water pump bearing
PETAMO GHY 133 N
Tried and tested for decades

Start-stop starter
Klübersynth EL 42-32
Low wear during constant operation

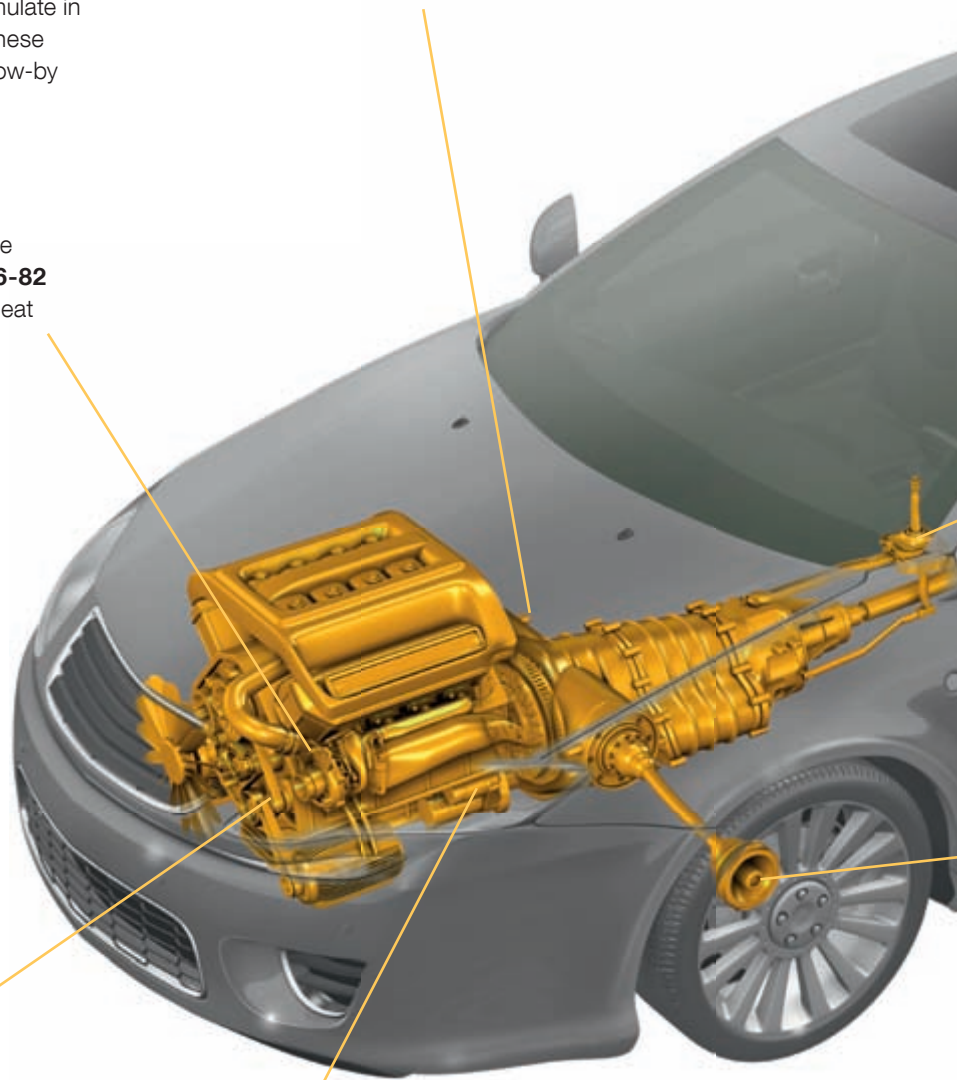

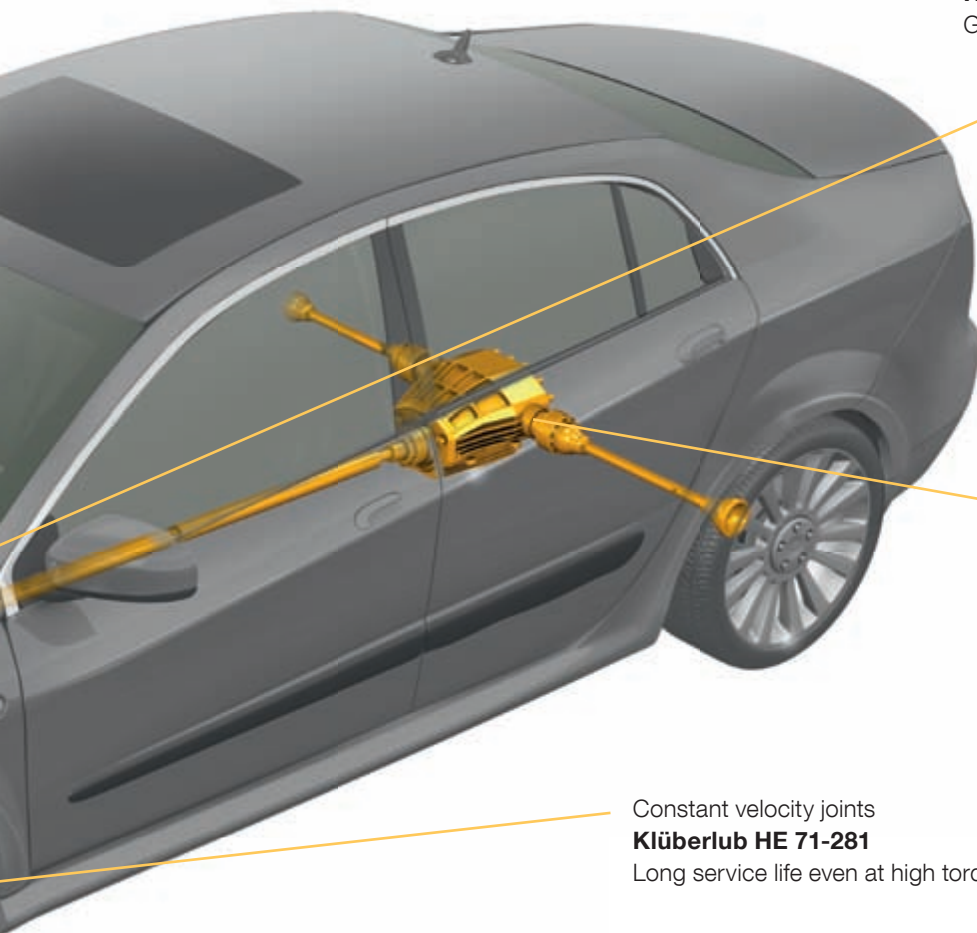

Gear shift selector
Klübersynth LIP 84-42
 Good haptics even at very low temperatures

Spline shafts
MICROLUBE GNY 202
 Minimises tribocorrosion

Constant velocity joints
Klüberlub HE 71-281
 Long service life even at high torques

Our customers

Audi, BMW, Bosch, Continental, Daimler, Delphi, Denso, DURA, ECS, Ford, FTE automotive, GAT, General Motors, GETRAG, GKN, GMB, Himmermann, Hyundai/KIA, Litens, Magneti Marelli, Mahle, Mazda, Mubea, NSK, NTN, PHA, PSA Peugeot Citroën, Scania, Schaeffler, SEAT, Teleflex, Toyota, TRW, Valeo, Voith, Volkswagen, Volvo, ZF

Product approvals

Bosch FS 18570-Ft, Bosch VS 10832-Ft, Bosch VS 18099-Ft, Brembo D1.04.18.000, Chrysler MS9958, Daimler DBL 6817.00, Daimler DBL 6827.31, Daimler DBL 6834.00, Ford ESA-M1C194-A, Ford ESD-M1C220-A, Ford ESF-M1C 43-A2, Ford WSD-M138P8A1, Ford WSD-M1C244-A, Opel B 0400043, Opel B 0400571, Opel B 0400882, Opel B 0401122, Opel B 0401138, Porsche 999.917.791.00, PSA B 71 3841, PSA X 10 1, PSA X 71 3100, PSA X 71 3102, PSA X 71 3134, Toyota TSK2520G, Toyota TSK2524G, VW-TL 52112, VW-TL 52141, VW-TL 52142, VW-TL 52147, VW-TL 52150, VW-TL52172, VW-TL 52528, VW-TL 751, VW-TL 760, VW-TL 767 X, VW-TL 776, VW-TL 778, ZF LMN 304

Please note that the a.m. information is only a small extract from our range of products and applications with no claim of completeness

Powertrain	Component requirements	lifetime lubrication	compatibility with polymers	resistance to water	resistance to fuel / blow-by condensates	dust & dirt capacity	no fretting / no tribocorrosion	wear protection & load carrying capacities	corrosion protection	
										Lube points
Drive shafts / Constant Velocity Joints	U-Joints	xx	x					xx		
	CVJ - Tripode Joint	xx	x					xx		
	CVJ - Plunging Ball Joint	xx	x					xx		
	CVJ - Fixed Ball Joint	xx	x					xx		
	Drive Shaft Spline	xx		x			xx	x	x	
Engine	Starter - Gear & Helical Spline	xx	x	x		xx		xx	x	
	Starter - Overrunning Clutch (ORC)	xx		x				xx		
	Starter - Solenoid Switch	xx				x			xx	
	Throttle / Throttle Control	xx			x			x	x	
	Idle Speed Actuator	xx								
	Alternator - Bearing		xx					xx		
	Belt Tensioner - Bushing	xx	x	x		x		xx		
	Pulleys - Bearing	xx	xx							
	Turbocharger Bolts / VTG Actuator	x					xx			
	EGR Actuator	xx	x		xx					
	Waste Gate Actuator	xx			xx					
	Intake Manifold Shaft - Seals / Actuator				xx					
	Water Pump Bearing		x	xx						
	Fuel Line Connectors				xx				x	
	Cooling Fluid Connectors			xx					x	
	Transmission & Clutch	Gear Shift Cable - Linkage	xx	xx						
		Spline Shaft						xx		xx
E-Clutch - Actuator		xx	x							
H-Clutch - Master / Slave Cylinder Seals		x	xx							
H-Clutch - Linkage Joints		xx	x	x		x				
Clutch Release Bearing		xx	x					xx	xx	
Dual Mass Flywheel		xx	x				xx	xx	x	

	wide temperature range	low friction & high efficiency	low break away & running torques	anti squeak & anti stick-slip	no hootnoise	Products
		x				Klüberplex BEM 41-141
	xx	x				Klüberplex BEM 41-141, Klüberlub HE 71-281
	xx	x				Klüberlub EH 71-241, Klüberlub HE 71-281
	xx	xx				Klüberlub EH 71-241, Klüberlub HE 71-281, Klüberlub EM 41-111, Klübersynth HIP 84-401
						DUOTEMPI PMY 45, MICROLUBE GL 261, MICROLUBE GNY 202
	xx					ISOFLEX LDS 18 Special A / A UV, Klübersynth EL 42-32, Klübersynth LP 42-32
	xx					ISOFLEX TOPAS NCA 52
	xx		xx			ISOFLEX M 2 JB
	xx	xx	xx			BARRIERTA KL 092 / KM 192, ISOFLEX TOPAS NCA 52, UNIMOLY C220
	xx	xx		x		Klübertemp GR M07
					xx	ASONIC HQ 72-102
	x			x		UNISILKON GLK 112
					xx	ASONIC HQ 72-102, Klübersynth BEP 72-82
	xx	x	x			BARRIERTA KL 092 / KM 192, Klüberpaste HEL 46-450, Klübertemp GR M07
	xx	x	x			BARRIERTA KL 092 / KM 192, BARRIERTA L 55/2 / L 55/0, Klübersynth BR 46-82, Klübertemp GR M07
	xx	x	x			BARRIERTA L 55/2 / L 55/0, Klübersynth BR 46-82
	x			xx		BARRIERTA KL 092 / KM 192, Klüber Noxlub KF 1920, Klüber Noxlub BF 2420, Klübertemp GR M07, Klübertemp GR M30
					x	PETAMO GHY 133 N
						Klüberalfa DH 3-350
	x	xx				Klüberplus S06-100
	x	xx				ISOFLEX TOPAS L 32 / L 32 N, Klübersynth LI 44-22, UNISILKON GLK 112
	x					MICROLUBE GL 261, MICROLUBE GNY 202
	xx	xx	x			Klübersynth BR 46-82, Klübersynth HIP 84-401
		x	x			Klübersynth HLR 46-371, SYNTHESO GLK 1
	xx	xx	xx	xx		Klüberalfa HM 83-801
			xx		xx	Klübersynth BEP 72-82, Klübersynth HB 72-102, PETAMO GY 193
	xx	xx		x		Klübersynth H 46-702, UNISILKON GLK 1301

Our products and their main characteristics

ALTEMP Q NB 50	lubricating paste with good wear protection
ASONIC HQ 72-102	high-temperature lubricating grease for low-noise rolling bearings
BARRIERTA KL 092 / KM 192	chemically inert PFPE products with excellent low temperature performance
BARRIERTA L 55/2 / L 55/0	chemically inert PFPE products with excellent media resistance
CENTOPLEX 24 DL / 1 DL	multi purpose low temperature grease
CENTOPLEX CX 3/350	shear stable lithium complex mineral oil grease, NLGI 0/1
CONSTANT GLY 2100	synthetic impregnating fluid for low-noise lubrication
CONSTANT OY K Series	synthetic hydrocarbon oils incorporating special additives for wide temp range
DUOTEMPI PMY 45	light-coloured high-pressure lubricating paste for frictionally engaged connections
ISOFLEX LDS 18 Special A / A/UV	dynamically light, long-term lubricating grease; version with UV Indicator available
ISOFLEX M 2 JB	special grease additivated against accelerated ageing in contact with non-ferrous metal
ISOFLEX TOPAS L 32 / L 32 N	the proven and tested synthetic low temperature grease in automotive industry
ISOFLEX TOPAS NB 5051	low temperature grease with excellent polymer compatibility (PA 66)
ISOFLEX TOPAS NB 52	synthetic grease with good high temperature performance, media resistance and compatibility with PA 66
ISOFLEX TOPAS NCA 52	synthetic long-term grease with low starting and running torques
Klüber Noxlub BF 2420	chemically inert PFPE product with excellent media resistance
Klüber Noxlub KF 1920	chemically inert PFPE products with excellent low temperature performance
Klüber Summit HySyn FG 68	synthetic hydrocarbon oil with good oxidation stability
Klüberalfa DH 3-230 N	PFPE product with very good media resistance and very good wetting properties
Klüberalfa DH 3-350	high-temperature lubricating oil with very good media resistance
Klüberalfa HM 83-801	high-temperature long-term and lifetime lubricating grease
Klüberalfa HX 83-301 / -302	long-term lubricating greases for seals, guides and rolling bearings subject to high loads
Klüberalfa IR 83-22	chemically inert PFPE product with excellent media resistance
Klüberalfa K 83-735	special dispersion for lubrication of plug-in contacts
Klüberalfa MR 3 Series	universal anti-friction fluids for seals, guides and plastic friction points in motor vehicles
Klüberalfa YM 3-30	PFPE oil with excellent polymer compatibility
Klüberbeta RM 47-102	lithium complex silicone grease with extremely low fogging tendency
Klüberbeta RM 47-291	anti-friction lubricant for pneumatic valve seals
Klüberflex 200-0 A/B	2-part coating for wiper blades with modular additive system to streamline performance
Klüberfluid 9 R 100	EPDM compatible assembly and anti-corrosion fluid with excellent wetting properties
Klübergrease LFT 71-402	water resistant polyurea grease with excellent corrosion protection
Klüberlectric KR 44-22 / -102 / -402	special greases for lubrication of electrical switches, contacts and sensors
Klüberlub EH 71-241	drive shaft joint grease - high temperature
Klüberlub EM 41-111	drive shaft joint grease - normal temperature
Klüberlub EM 41-142	high performance grease with excellent anti wear properties
Klüberlub HE 71-281	drive shaft joint grease - high efficiency, high temperature



Klüberlub LM 41-102	high performance grease with self locking properties
Klüberlub LM 41-32 N	low temperature grease with self locking properties
Klüberoil 4 UH 1-32 N	NSF H1 registered synthetic hydrocarbon oil
Klüberoil 4 UH 1-150 N/...-450 N	synthetic hydrocarbon oils with food grade certification
Klüberpaste 46 MR 401	EPDM compatible high temperature paste - medium base oil viscosity
Klüberpaste HEL 46-450	high temperature bolt and screw paste
Klüberpaste UH1 84-201	NSF H1 registered adhesive paste for long-term lubrication
Klüberplex BEM 34-132 /-131N	synthetic hub unit bearing greases with excellent false brinelling protection
Klüberplex BEM 41-132	mineral oil general purpose hub unit grease
Klüberplex BEM 41-141	joint grease for high temperature
Klüberplex RA 41-151	Special grease for odour-sensitive applications
Klüberplus S 02-004	water-miscible anti-friction dispersion for windscreen wipers
Klüberplus S 06-100	water soluble assembly aid - based on silica gel
Klübersynth BEP 72-82	rolling bearing grease for long-term lubrication
Klübersynth BLR 46-122	non-silicone grease for brake booster seal and valve lubrication
Klübersynth BM 44-42	special grease for freewheels, linear guides and four point bearings
Klübersynth BME 44-42	special grease for ball screws with very high load
Klübersynth BR 46-32 F	low-friction grease without silicone-based raw materials with very wide service temperature range
Klübersynth BR 46-82	lithium complex grease without silicone-based raw materials with very wide service temperature range and excellent wear resistance
Klübersynth EL 42-32	start-stop starter grease with excellent life time performance
Klübersynth GE 14-111	synthetic gear grease with excellent load carrying capacities
Klübersynth H 46-702	DMF grease with very low oil separation
Klübersynth HB 72-102	synthetic rolling bearing grease with exceptional corrosion protection
Klübersynth HB 72-52	EPDM compatible bearing grease with a wide service temperature range
Klübersynth HB 74-401	synthetic polyurea grease for high loads and good wear protection
Klübersynth HIP 84-401	high-temperature grease with excellent damping properties for friction pairings subject to high loads
Klübersynth HLR 46-371	universal polyglycol grease for hydraulic brake and clutch systems
Klübersynth J 44-402	synthetic ball joint lubricant with low break away torque
Klübersynth JIP 84-402	synthetic anti stick-slip grease
Klübersynth LE 14-161	synthetic high efficiency gear grease - based on aluminium complex soap
Klübersynth LE 44-31	synthetic high efficiency gear grease - based on lithium soap
Klübersynth LF 44-22	synthetic low temperature & low friction lubricant
Klübersynth LI 44-22	synthetic low temperature grease with good damping properties
Klübersynth LIP 84-42	synthetic low temperature & low friction lubricant with good haptic damping properties

Our products and their main characteristics

Klübersynth LP 42-32	starter grease with excellent life time performance in plastic gears
Klübersynth LR 44-21	low temperature grease with good noise dampening
Klübersynth MR 96-31	low temperature grease with excellent polymer compatibility (PP, HDPE, etc.)
Klübersynth P 84-52 G	synthetic low temp PTFE paste with excellent dust & dirt capacity
Klübersynth RA 44-3502	good compatibility with plastics; for noise reduction and high mechanical damping of low-speed components
Klübersynth RA 44-702	good compatibility with plastics; for noise reduction and medium mechanical damping of low-speed components
Klübersynth RM 14-211	anti friction lubricant for shock absorber seals
Klübertemp GR M07	chemically inert PFPE product with excellent viscosity index - extreme low temp performance
Klübertemp GR M30	chemically inert PFPE product with excellent viscosity index - low temp performance
Klübertemp RHB 83-202	chemically inert PFPE product with good media resistance and EPDM compatibility
Klübertop TM 06-111	1-part coating with very good corrosion protection
Klübertop TP 03-111	1-part heat curing bonded coating
Klübertop TP 18-810 N	1-part coating specially made for flocked profiles
Klübertop TP 22-1310 A/B	water-miscible 2-part coating for automotive body seals
Klübertop TP 39-311 A/B	2-part PTFE bonded coating for metal components
KONTASYNTH BA 100 SPRAY	gliding spray for contacts, seals, guides and plastic friction points
MICROLUBE GL 261	special grease for boundary friction conditions and tribo-corrosion
MICROLUBE GNY 202	special grease for boundary friction conditions and tribo-corrosion
MIKROZELLA Series	unique depot lubricants for lifetime enhancement of sintered bearings
NONTROP GB 3 G	dust cap assembly grease for drum brake slave cylinders with good high temperature performance
OPTAPLUS AO 35	high performance damping grease
PETAMO GHY 133 N	water pump bearing grease
PETAMO GY 193	roller bearing grease for the high-temperature and long-term lubrication
POLYLUB GA 352 P	standard lubricant for shock absorber seals
POLYLUB GLY 151	semisynthetic lithium complex grease with excellent plastic compatibility and good adhesion - low viscosity
POLYLUB GLY 501	semisynthetic lithium complex grease with excellent plastic compatibility and good adhesion - medium viscosity
POLYLUB GLY 801	semisynthetic lithium complex grease with excellent plastic compatibility and good adhesion - high viscosity
QUIETSCH-EX	universal anti-squeak fluid
STABUTHERM GH 461	polyurea grease for high loads and good water resistance
SYNTHESO GLEP 1	EPDM compatible grease for brake components and hydraulic seals
SYNTHESO GLK 1	EPDM compatible grease for brake components and hydraulic seals



SYNTHESO GLK 1 PF	EPDM compatible grease for brake components and hydraulic seals - PTFE fortified
UNIMOLY C 220	High-pressure resistant hygrosetting bonded coating
UNISILKON GLK 112	lithium complex silicone grease with multiple OEM approvals
UNISILKON GLK 1301	DMF grease based on silicone oil
WOLFRAKOTE TOP PASTE	high temperature anti-seizing paste



Publisher and Copyright:

Klüber Lubrication München SE & Co. KG

Reprints, total or in part, are permitted only prior consultation with Klüber Lubrication München SE & Co. KG and if source is indicated and voucher copy is forwarded.

The data in this document is based on our general experience and knowledge at the time of publication and is intended to give information of possible applications to a reader with technical experience. It constitutes neither an assurance of product properties nor does it release the user from the obligation of performing preliminary field tests with the product selected for a specific application. All data are guide values which depend on the lubricant's composition, the intended use and the application method. The technical values of lubricants change depending on the mechanical, dynamical, chemical and thermal loads, time and pressure. These changes may affect the function of a component. We recommend contacting us to discuss your specific application. If possible we will be pleased to provide a sample for testing on request. Products from Klüber Lubrication are continually improved. Therefore, Klüber Lubrication reserves the right to change all the technical data in this document at any time without notice.

Klüber Lubrication München SE & Co. KG
Geisenhausenerstraße 7
81379 München
Germany

Local first-instance court Munich, Germany
Certificate of registration 46624

www.klueber.com

Klüber Lubrication – your global specialist

Innovative tribological solutions are our passion. Through personal contact and consultation, we help our customers to be successful worldwide, in all industries and markets. With our ambitious technical concepts and experienced, competent staff we have been fulfilling increasingly demanding requirements by manufacturing efficient high-performance lubricants for more than 80 years.

a brand of
 **FREUDENBERG**