

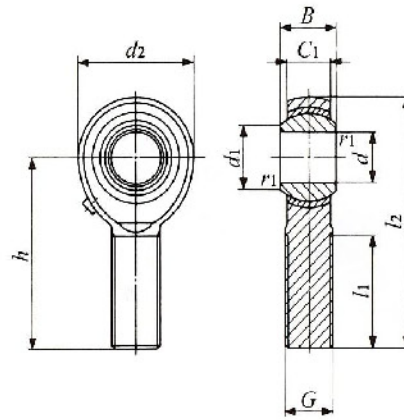

**Stainless steel pillowball rod end with male thread**



**Dimension table . Dimension in mm**

Identification number	Mass (Ref.) g	Boundary dimensions mm										Basic load rating		
		d	Thread G	d <sub>2</sub>	C <sub>1</sub>	B	d <sub>1</sub>	l <sub>2</sub>	h	l <sub>1</sub>	r <sub>1smin</sub>	Ball dia. mm	dyn. Cd N	stat. Cs N
SSPOS 3	5	3	M3 x 0.5	12	4.5	6	5.2	33	27	15	0.2	7.938	1 662	1 159
SSPOS 4	8.1	4	M4 x 0.7	14	5.3	7	6.5	37	30	17	0.2	9.525	2 356	1 957
SSPOS 5	12.5	5	M5 x 0.8	16	6	8	7.7	41	33	20	0.2	11.112	3 106	3173
SSPOS 6	19	6	M6 x 1	18	6.75	9	9	45	36	22	0.2	12.700	3 990	4 493
SSPOS 8	32	8	M8 x 1.25	22	9	12	10.4	53	42	25	0.2	15.875	6 659	8 208
SSPOS 10	54	10	M10 x 1.5	26	10.5	14	12.9	61	48	29	0.2	19.050	9 319	12 635
SSPOS 12	85	12	M12 x 1.75	30	12	16	15.4	69	54	33	0.2	22.225	12 445	16 055
SSPOS 14	126	14	M14 x 2	34	13.5	19	16.9	77	60	36	0.2	25.400	15 960	19 855
SSPOS 16	185	16	M16 x 2	38	15	21	19.4	85	66	40	0.2	28.575	19 950	24 130
SSPOS 18	260	18	M18 x 1.5	42	16.5	23	21.9	93	72	44	0.2	31.750	24 415	28 690
SSPOS 20	340	20	M20 x 1.5	46	18	25	24.4	101	78	47	0.2	34.925	29 260	33 725
SSPOS 22	435	22	M22 x 1.5	50	20	28	25.8	109	84	51	0.2	38.100	35 530	39 615
SSPOS 25	650	25	M24 x 2	60	22	31	29.6	124	94	57	0.6	42.862	43 890	69 065
SSPOS 28	875	28	M27 x 2	66	25	35	32.3	136	103	62	0.6	47.625	55 480	82 650
SSPOS 30	1070	30	M30 x 2	70	25	37	34.8	145	110	66	0.6	50.800	59 185	87 590

- Bearing with a stretching rod, stretching rod with right or left - hand male thread.  
(For left - hand thread, suffix L)
- The surface of spherical of rod body.
- The housing with a lubrication hole or a grease nipple.
- The front " SS " stands for body and ball is made of stainless steel.



**Stainless steel pilloball rod end with female thread**

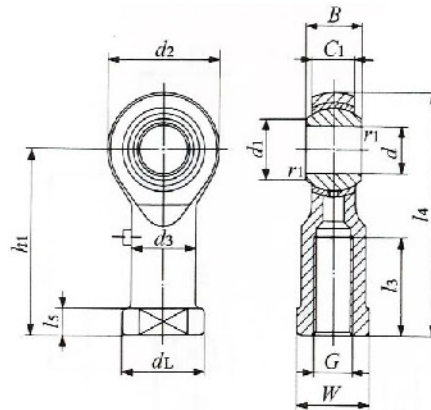

**Dimension table . Dimension in mm**

Identification number	Mass (Ref.) g	Boundary dimensions mm														Basic load rating		
		d	Thread G	d <sub>2</sub>	C <sub>1</sub>	B	d <sub>1</sub>	l <sub>4</sub>	h <sub>1</sub>	l <sub>3</sub>	l <sub>5</sub>	W	d <sub>3</sub>	d <sub>L</sub>	r <sub>1smin</sub>	Ball dia. mm	dyn. Cd N	stat. Cs N
SSPHS 3	5.7	3	M3X0.5	12	4.5	6	5.2	27	21	10	3	5.5	5	6.5	0.2	7.938	1 662	3 486
SSPHS 4	11.9	4	M4X0.7	14	5.3	7	6.5	31	24	12	4	8	8	9.5	0.2	9.525	2 356	4 446
SSPHS 5	16.5	5	M5X0.8	16	6	8	7.7	35	27	14	4	9	9	11	0.2	11.112	3 106	5 443
SSPHS 6	25	6	M6X1	18	6.8	9	9	39	30	14	5	11	10	13	0.2	12.700	3 990	6 564
SSPHS 8	43	8	M8X1.25	22	9	12	10.4	47	36	17	5	14	12.5	16	0.2	15.875	6 659	9 690
SSPHS 10	72	10	M10X1.5	26	11	14	12.9	56	43	21	6.5	17	15	19	0.2	19.050	9 319	12 635
SSPHS 12	107	12	M12X1.75	30	12	16	15.4	65	50	24	6.5	19	17.5	22	0.2	22.225	12 445	16 055
SSPHS 14	160	14	M14X2	34	14	19	16.9	74	57	27	8	22	20	25	0.2	25.400	15 960	19 855
SSPHS 16	210	16	M16X2	38	15	21	19.4	83	64	33	8	22	22	27	0.2	28.575	19 950	24 130
SSPHS 18	295	18	M18X1.5	42	17	23	21.9	92	71	36	10	27	25	31	0.2	31.750	24 415	28 690
SSPHS 20	380	20	M20X1.5	46	18	25	24.4	100	77	40	10	30	27.5	34	0.2	34.925	29 260	33 725
SSPHS 22	490	22	M22X1.5	50	20	28	25.8	109	84	43	12	32	30	37	0.2	38.100	35 530	39 615
SSPHS 25	750	25	M24X2	60	22	31	29.6	124	94	48	12	36	33.5	42	0.6	42.862	43 890	69 065
SSPHS 28	950	28	M27X2	66	25	35	32.3	136	103	53	12	41	37	46	0.6	47.625	55 480	82 650
SSPHS 30	1 130	30	M30X2	70	25	37	34.8	145	110	56	15	41	40	50	0.6	50.800	59 185	87 590

- Bearing with a stretching rod, stretching rod with right or left - hand female thread.  
(For left - hand thread, suffix L)
- The surface of spherical of rod body.
- The housing with a lubrication hole or a grease nipple.A4
- The front " SS " stands for body and ball is made of stainless steel.