



# Spline Nut

THK General Catalog

## A Product Descriptions

<b>Features</b> .....	A14-2
Features of the Spline Nut.....	A14-2
• Structure and Features .....	A14-2
• Features of the Special Rolled Shafts..	A14-3
• High Strength Zinc Alloy.....	A14-3
• Clearance in the Rotation Direction ....	A14-4
<b>Point of Selection</b> .....	A14-5
Selecting a Spline Nut .....	A14-5
<b>Dimensional Drawing, Dimensional Table</b>	
Model DPM.....	A14-8
Model DP.....	A14-10
<b>Point of Design</b> .....	A14-12
Fit.....	A14-12
Installation .....	A14-12
Lubrication .....	A14-13
<b>Model No.</b> .....	A14-14
• Model Number Coding.....	A14-14
• Notes on Ordering.....	A14-14
<b>Precautions on Use</b> .....	A14-15

## B Support Book (Separate)

<b>Features</b> .....	B14-2
Features of the Spline Nut.....	B14-2
• Structure and Features .....	B14-2
• Features of the Special Rolled Shafts..	B14-3
• High Strength Zinc Alloy.....	B14-3
• Clearance in the Rotation Direction ....	B14-4
<b>Point of Selection</b> .....	B14-5
Selecting a Spline Nut .....	B14-5
• Calculating the Sliding Speed V .....	B14-7
• Example of calculation .....	B14-7
<b>Maintenance</b> .....	B14-8
Lubrication .....	B14-8
<b>Model No.</b> .....	B14-9
• Model Number Coding.....	B14-9
• Notes on Ordering.....	B14-9
<b>Precautions on Use</b> .....	B14-10

## Features of the Spline Nut

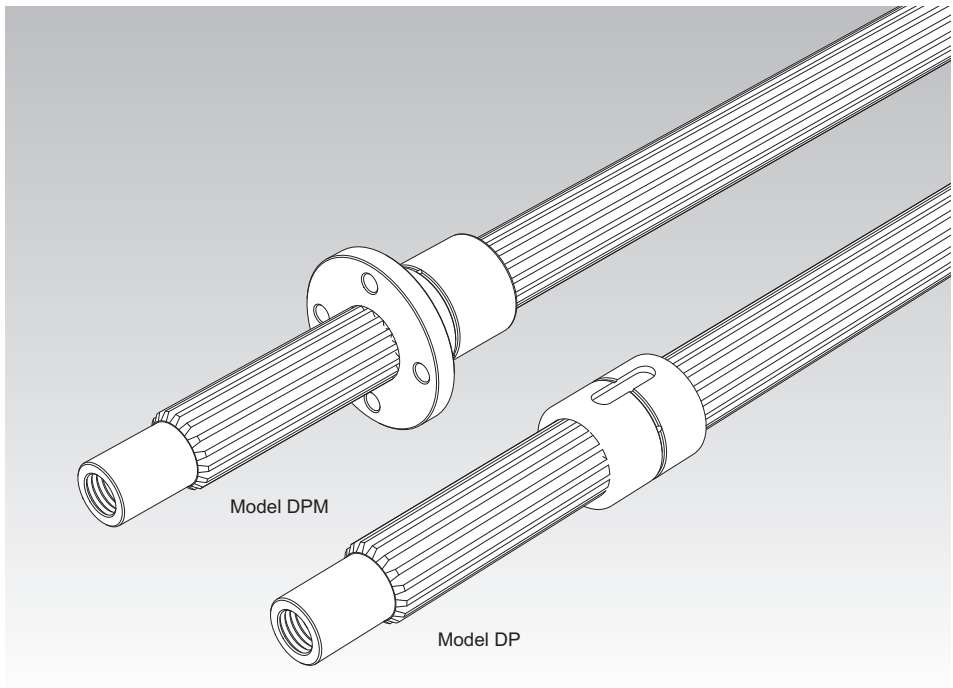

### Structure and Features

Spline Nut models DPM and DP are low price bearings that are made of a special alloy (see **A14-3**) formed by die casting and use highly accurate spline shafts as the core. Unlike conventional machined spline nuts, the sliding surface of these models maintains a chill layer formed in the rolling process, thus achieving high wear resistance.

The surface of the spline shafts to be used in combination with the nuts is hardened through rolling and is mirror-finished. Accordingly, smooth sliding motion is achieved.

The specially designed teeth of the spline have large contact areas, as well as concentricity, which enable the shaft to automatically establish the center as a torque is applied. Therefore, the teeth demonstrate stable performance in transmitting a torque.

## Features of the Special Rolled Shafts

Dedicated rolled shafts with standardized lengths are available for the Spline Nut.

### [Increased Wear Resistance]

The shaft teeth are formed by cold gear rolling, and the surface of the tooth surface is hardened to over 250 HV and mirror-finished. As a result, the shafts are highly wear resistant and achieve significantly smooth motion when used in combination with nuts.

### [Improved Mechanical Properties]

Inside the teeth of the rolled shaft, a fiber flow occurs along the contour of the tooth surface of the shaft, making the structure around the teeth roots dense. As a result, the fatigue strength is increased.

### [Additional Machining of the Shaft End Support]

Since each shaft is rolled, additional machining of the support bearing of the shaft end can easily be performed by lathing or milling.

## High Strength Zinc Alloy

The high strength zinc alloy used in the spline nuts is a material that is highly resistant to seizure and wear and has a high load carrying capacity. Information on mechanical properties, physical properties, and wear resistance is presented below.

\* The figures shown are target values—these figures are not guaranteed.

### [Mechanical Properties]

Table1

Item	Description
Tensile strength	275 to 314 N/mm <sup>2</sup>
Tensile yield strength (0.2%)	216 to 245 N/mm <sup>2</sup>
Compressive strength	539 to 686 N/mm <sup>2</sup>
Compressive yield strength (0.2%)	294 to 343 N/mm <sup>2</sup>
Fatigue strength	132 N/mm <sup>2</sup> × 10 <sup>7</sup> (Schenk bending test)
Charpy impact	0.098 to 0.49 N-m/mm <sup>2</sup>
Elongation	1 to 5 %
Hardness	120 to 145 HV

## [Physical Properties]

Table2

Item	Description
Specific gravity	6.8
Specific heat	460 J/ (kg•K)
Melting point	390 °C
Thermal expansion coefficient	$24 \times 10^{-6}$

## [Wear Resistance]

Table3 [Test conditions: Amsler wear-tester]

Item	Description
Test piece rotational speed	185 min <sup>-1</sup>
Load	392 N
Lubricant	Dynamo oil

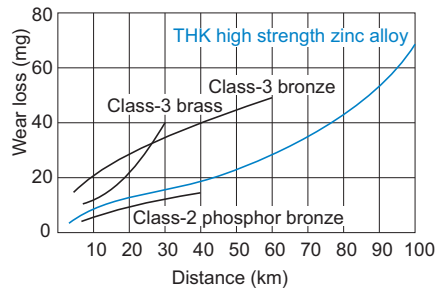

Fig.1 Wear Resistance of the High Strength Zinc Alloy

## Clearance in the Rotation Direction

Clearance in the rotational direction:  $\alpha \leq 20'$  MAX

## Selecting a Spline Nut

### [Dynamic Permissible Torque T]

The permissible dynamic torque (T) is the torque at which the contact surface pressure on the bearing tooth surface is  $9.8 \text{ N/mm}^2$ . These values are used as a reference for the strength of the spline nut.

### [pV Value]

With a sliding bearing, a pV value, which is the product of the contact surface pressure (p) and the sliding speed (V), is used as a measuring stick to judge whether the assumed model can be used. Use the corresponding pV value indicated in Fig.1 as a guide for selecting a spline nut. The pV value also varies according to the lubrication conditions.

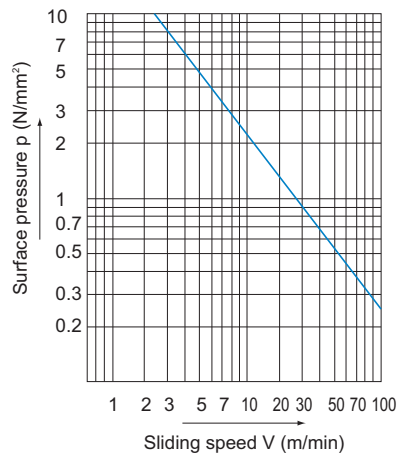

Fig.1 pV Value

Table1 Safety Factor ( $f_s$ )

Type of load	Lower limit of $f_s$
For a static load less frequently used	1 to 2
For an ordinary single-directional load	2 to 3
For a load accompanied by vibrations/impact	4 or greater

### ● $f_s$ : Safety Factor

To calculate a load applied to the spline nut, it is necessary to accurately obtain the effect of the inertia that changes with the weight and dynamic speed of an object. In general, with reciprocating or rotating machines, it is not easy to accurately obtain all the factors such as the effect of the start and stop, which are always repeated. Therefore, if the actual load cannot be obtained, it is necessary to select a bearing while taking into account the empirically obtained safety factors ( $f_s$ ) shown in Table1.

### ● $f_T$ : Temperature Factor

If the temperature of the spline nut exceeds the normal temperature range, the seizure resistance of the nut and the strength of the material will decrease. Therefore, it is necessary to multiply the dynamic permissible torque ( $T$ ) by the corresponding temperature factor indicated in Fig.2.

Accordingly, when selecting a spline nut, the following equations need to be met in terms of its strength.

Dynamic permissible torque ( $T$ )

$$f_s \leq \frac{f_T \cdot T}{P_T}$$

$f_s$  : Static safety factor

(see Table1 on **A14-5**)

$f_T$  : Temperature factor (see Fig.2)

$T$  : Dynamic permissible torque (N-m)

$P_T$  : Applied torque (N-m)

### ● Hardness of the Surface and Wear Resistance

The hardness of the shaft significantly affects the wear resistance of the spline nut. If the hardness is equal to or less than 250 HV, the abrasion loss increases as indicated in Fig.3. The roughness of the surface should preferably be Ra0.80 or less.

A specially rolled shaft achieves surface hardness of 250 HV or greater, through hardening as a result of rolling, and a surface roughness of Ra0.20 or less. Thus, the dedicated rolled shaft is highly wear resistant.

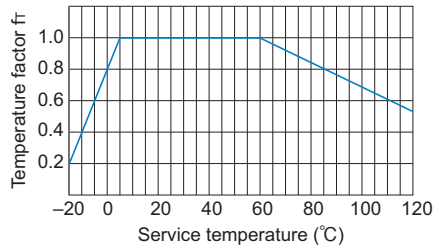

Fig.2 Temperature factor

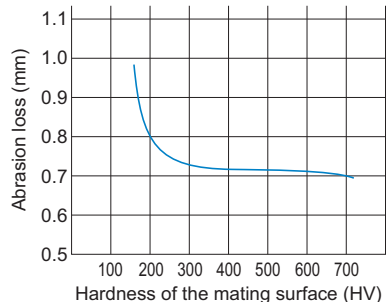

Fig.3 Hardness of the Surface and Wear Resistance

### [Calculating the Contact Surface Pressure $p$ ]

$$p = \frac{P_T}{T} \times 9.8$$

$p$  : Contact surface pressure on the tooth under a load torque ( $P_T$ ) (N/mm<sup>2</sup>)

$T$  : Dynamic permissible torque (N-m)

$P_T$  : Applied torque (N-m)

**Point of Selection**

## Selecting a Spline Nut

**[Calculating the Sliding Speed V]**

With splines, the sliding speed of the tooth surface is equal to the feeding speed.

V : Sliding speed of the tooth (m/min)

# Model DPM

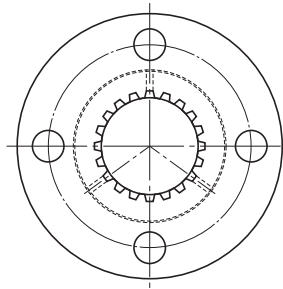

Spline Nut  Model No.	Outer dimensions			Spline nut dimensions						
	Outer diameter		Length L	Flange diameter D <sub>1</sub>	H	B	PCD	r	F	d
	D	Tolerance h9								
DPM 1220	22	0 -0.052	20	44	6	5.4	31	1.5	7	1.5
DPM 1230			30							
DPM 1520	22	0 -0.052	20	44	6	5.4	31	1.5	7	1.5
DPM 1530			30							
DPM 1723	28	0 -0.052	23	51	7	6.6	38	1.5	8	1.5
DPM 1735			35							
DPM 2028	32	0 -0.062	28	56	7	6.6	42	1.5	10.5	1.5
DPM 2040			40							
DPM 2536	36	0 -0.062	36	61	8	6.6	47	2	14	2
DPM 2550			50							
DPM 3040	44	0 -0.074	40	76	10	9	58	2	15	2
DPM 3056			56							
DPM 3544	52	0 -0.074	44	84	10	9	66	2.5	17	2.5
DPM 3560			60							
DPM 4050	58	0 -0.074	50	98	12	11	76	2.5	19	3
DPM 4068			68							
DPM 4555	64	0 -0.074	55	104	12	11	80	2.5	21.5	3
DPM 4575			75							
DPM 5060	68	0 -0.074	60	109	12	11	85	2.5	24	3.5
DPM 5080			80							

Note) The dynamic permissible torque (T) indicates the torque at which the contact surface pressure on the spline teeth is 9.8 N/mm<sup>2</sup>.

Clearance in the rotational direction:  $\alpha \leq 20'$  MAX

If multiple spline nuts are to be mounted on a single shaft, please note that the locations of flange mounting holes and key grooves on the respective spline nuts may vary slightly.

Avoid specifications that would require fitting multiple spline nuts to a single housing.

## Model number coding

Combination of spline nut and spline shaft

## 2 DPM2040 +360L

Overall spline shaft length (in mm)

Model No. of spline nut

Number of spline nuts used on the same shaft



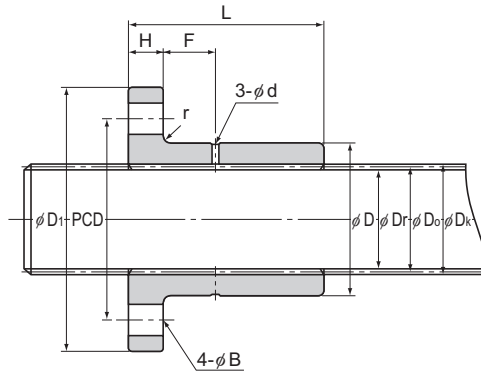

Unit: mm

	Spline shaft	Spline details				Standard shaft length	Maximum shaft length	Dynamic permissible torque $T_{Note}$ N-m	Mass	
		Pitch diameter $D_0$	Major diameter $D_1$	Minor diameter $D_2$	Number of teeth $Z$				Spline Nut g	Spline Shaft kg/m
	SS 12	12	12.8	10.9	16	1500	17.6 26.5	80 90	0.9	
	SS 15	15	16.1	13.5	16	1500	30.4 46.1	70 80	1.4	
	SS 17	17	18.2	15.4	16	1500	43.1 65.7	120 150	1.7	
	SS 20	20	21.5	18.3	16	1500	70.6 100	160 200	2.5	
	SS 25	25	26.9	22.6	16	1500	152 211	220 270	3.8	
	SS 30	30	31.8	28.2	20	1500	212 297	400 480	5.5	
	SS 35	35	37.1	32.8	20	1500	325 443	560 670	7.5	
	SS 40	40	42.4	37.5	20	1500	480 673	830 970	9.8	
	SS 45	45	47.7	42.1	20	1500	680 927	980 1110	12.4	
	SS 50	50	53	46.8	20	1500	910 1220	1080 1290	15.4	

Spline Nut

## Model number coding

Spline shaft

**SS20 +1500L**

Overall spline shaft length (in mm)

Model number of spline shaft

# Model DP

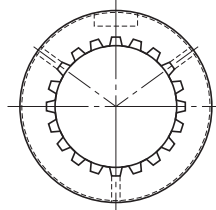

Spline Nut  Model No.	Outer dimensions			Spline nut dimensions					
	Outer diameter		L	Keyway dimensions					
	D	Tolerance h9		0	b	Tolerance N9	t	ℓ	d
DP 12	22	-0.052	22	4	-0.030	2	16	1.5	1
DP 15	22		22	4		2	16	1.5	1
DP 17	28	-0.062	26	5	-0.036	2.5	18	1.5	1
DP 20	32		31	7		2.5	22	1.5	1
DP 25	36	-0.074	40	7	-0.043	2.5	26	2	1
DP 30	44		45	10		4	32	2	1.5
DP 35	52	-0.074	49	12	-0.043	4.5	40	2.5	1.5
DP 40	58		57	15		5	42	3	1.5
DP 45	64	-0.074	62	15	-0.043	5	48	3	1.5
DP 50	68		67	15		5	52	3.5	1.5

Note) The dynamic permissible torque (T) indicates the torque at which the contact surface pressure on the spline teeth is 9.8 N/mm<sup>2</sup>.  
 Clearance in the rotational direction:  $\alpha \leq 20'$  MAX  
 If multiple spline nuts are to be mounted on a single shaft, please note that the locations of flange mounting holes and key grooves on the respective spline nuts may vary slightly.  
 Avoid specifications that would require fitting multiple spline nuts to a single housing.

## Model number coding

Combination of spline nut and spline shaft

**2 DP20 +360L**

Overall spline shaft length (in mm)

Model No. of spline nut

Number of spline nuts used on the same shaft

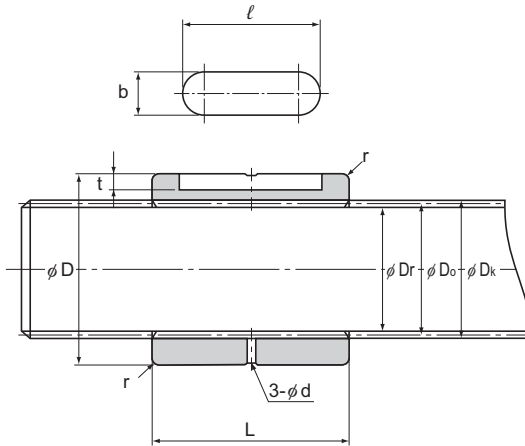

Unit: mm

Spline shaft	Spline details				Standard shaft length	Maximum shaft length	Dynamic permissible torque $T^{\text{Note}}$ N-m	Mass	
	Model No.	Pitch diameter $D_o$	Major diameter $D_k$	Minor diameter $D_r$				Number of teeth Z	Spline Nut g
SS 12	12	12.8	10.9	16	1500	1500	19.6	40	0.9
SS 15	15	16.1	13.5	16	1500	2000	33.3	30	1.4
SS 17	17	18.2	15.4	16	1500	2000	48	65	1.7
SS 20	20	21.5	18.3	16	1500	3200	77.5	100	2.5
SS 25	25	26.9	22.6	16	1500	3200	169	135	3.8
SS 30	30	31.8	28.2	20	1500	3200	238	230	5.5
SS 35	35	37.1	32.8	20	1500	3200	362	360	7.5
SS 40	40	42.4	37.5	20	1500	3200	547	510	9.8
SS 45	45	47.7	42.1	20	1500	3200	767	640	12.4
SS 50	50	53	46.8	20	1500	3200	1020	710	15.4

Spline Nut

## Model number coding

Spline shaft

**SS20 +1500L**

Overall spline shaft length (in mm)

Model number of spline shaft

## Fit

For the fitting between the spline nut outer diameter and the housing, we recommend a loose fit.  
Housing inner-diameter tolerance: G7

## Installation

### [About Chamfer of the Housing's Mouth]

To increase the strength of the root of the flange of the spline nut, the corner is machined to have an R shape. Therefore, it is necessary to chamfer the inner edge of the housing's mouth.

Table1 Chamfer of the Housing's Mouth

Unit: mm

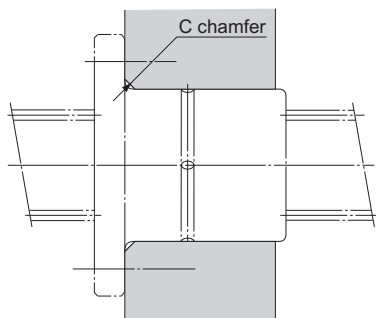

Fig.1

Model No.	Chamfer of the mouth C (Min.)
DPM	
12	2
15	
17	
20	
25	2.5
30	
35	3
40	
45	
50	

# Lubrication

Select a lubrication method according to the conditions of the spline nut.

## [Oil Lubrication]

For the lubrication of the spline nut, oil lubrication is recommended. Specifically, oil-bath lubrication or drop lubrication is particularly effective. Oil-bath lubrication is the most appropriate method since it meets harsh conditions such as high speed, heavy load or external heat transmission, and it cools the spline nut. Drop lubrication suits low to medium speed and a light to medium load. Select a lubricant according to the conditions as indicated in Table2.

Table2 Selection of a Lubricant

Condition	Types of Lubricants
Low speed, high load, high temperature	High-viscosity sliding surface oil or turbine oil
Low speed, light load, low temperature	Low-viscosity sliding surface oil or turbine oil

## [Grease Lubrication]

In low-speed feed, which occurs less frequently, the user can lubricate the slide system by manually applying grease to the shaft on a regular basis or using the greasing hole on the spline nut. We recommend using lithium-soap group grease No. 2.

## Model Number Coding

Model number configurations differ depending on the model features. Refer to the corresponding sample model number configuration.

### [Spline Nut]

#### ● Models DP, DPM and SS

- Spline Nut only

**DPM2040**

Model No. of spline nut

- Spline shaft only

**SS20 +1500L**

Overall spline shaft length (in mm)  
Model number of spline shaft

- Combination of spline nut and spline shaft

**2 DPM2040 +360L**

Overall spline shaft length (in mm)  
Model No. of spline nut  
Number of spline nuts used on the same shaft

## Notes on Ordering

If multiple spline nuts are to be mounted on a single shaft, please note that the locations of flange mounting holes and key grooves on the respective spline nuts may vary slightly. Avoid specifications that would require fitting multiple spline nuts to a single housing.

**[Handling]**

- (1) Tilting a spline nut or spline shaft may cause them to fall by their own weight.
- (2) Make sure the spline nut is not dropped or subjected to any sudden impact, as this could cause injury and damage the product. Even if there is no outward indication of damage, a sudden impact could prevent the unit from functioning properly.
- (3) When handling the product, wear protective gloves, safety shoes, etc., as necessary to ensure safety.

**[Precautions on Use]**

- (1) Prevent foreign material, such as cutting chips or coolant, from entering the product. Failure to do so may cause damage.
- (2) If the product is used in an environment where cutting chips, coolant, corrosive solvents, water, etc., may enter the product, use bellows, covers, etc., to prevent them from entering the product.
- (3) If foreign material such as cutting chips adheres to the product, replenish the lubricant after cleaning the product.
- (4) Do not forcibly drive a pin, key, or other positioning device into this product; this could create indentations on the sliding surface and impair the product's function.
- (5) Skewing or misalignment of the spline shaft support and spline nut can shorten service life substantially. Inspect the components carefully and make sure they are mounted correctly.
- (6) Insufficient rigidity or accuracy of mounting members causes the bearing load to concentrate on one point and the bearing performance will drop significantly. Accordingly, give sufficient consideration to the rigidity/accuracy of the housing and base and strength of the fixing bolts.

**[Lubrication]**

- (1) Thoroughly wipe off anti-rust oil and feed lubricant before using the product.
- (2) Do not mix different lubricants. Mixing greases using the same type of thickening agent may still cause adverse interaction between the two greases if they use different additives, etc.
- (3) When using the product in locations exposed to constant vibrations or in special environments such as clean rooms, vacuum and low/high temperature, use the grease appropriate for the specification/environment.
- (4) Following lubrication, perform several warm-up strokes with the unit to ensure that lubricant permeates the interior.
- (5) Lubricant viscosity can vary depending on the temperature. Please keep in mind that the spline nut's sliding resistance may be affected by changes in viscosity.
- (6) Following lubrication, stirring-resistance within the lubricant can cause the spline nut to exhibit increased sliding resistance. Before commencing operations, make sure to run the unit through several warm-up cycles to ensure that the lubricant is adequately integrated and dispersed.
- (7) Excess grease may scatter immediately after lubrication, so wipe off scattered grease as necessary.
- (8) The properties of grease deteriorate and its lubrication performance drops over time, so grease must be checked and added properly according to the use frequency of the machine.
- (9) The greasing interval varies depending on the use condition and service environment. Set the final lubrication interval/amount based on the actual machine.
- (10) If a lubricant will be used, the application must be designed in such a way that the spline nut's mounting position does not prevent lubricant from circulating.

**[Storage]**

Spline nuts should be stored horizontally in their original packaging in an indoor location where they are not exposed to abnormally high or low temperatures or high humidity.

**[Disposal]**

Dispose of the product properly as industrial waste.





# Spline Nut

THK General Catalog

## B Support Book

<b>Features</b> .....	A14-2
Features of the Spline Nut.....	A14-2
• Structure and Features .....	A14-2
• Features of the Special Rolled Shafts..	A14-3
• High Strength Zinc Alloy.....	A14-3
• Clearance in the Rotation Direction ....	A14-4
<b>Point of Selection</b> .....	A14-5
Selecting a Spline Nut .....	A14-5
• Calculating the Sliding Speed V .....	A14-7
• Example of calculation .....	A14-7
<b>Maintenance</b> .....	A14-8
Lubrication .....	A14-8
<b>Model No.</b> .....	A14-9
• Model Number Coding .....	A14-9
• Notes on Ordering.....	A14-9
<b>Precautions on Use</b> .....	A14-10

## A Product Descriptions (Separate)

<b>Features</b> .....	A14-2
Features of the Spline Nut.....	A14-2
• Structure and Features .....	A14-2
• Features of the Special Rolled Shafts..	A14-3
• High Strength Zinc Alloy.....	A14-3
• Clearance in the Rotation Direction ....	A14-4
<b>Point of Selection</b> .....	A14-5
Selecting a Spline Nut .....	A14-5
<b>Dimensional Drawing, Dimensional Table</b>	
Model DPM.....	A14-8
Model DP.....	A14-10
<b>Point of Design</b> .....	A14-12
Fit.....	A14-12
Installation .....	A14-12
Lubrication .....	A14-13
<b>Model No.</b> .....	A14-14
• Model Number Coding .....	A14-14
• Notes on Ordering.....	A14-14
<b>Precautions on Use</b> .....	A14-15

## Features of the Spline Nut

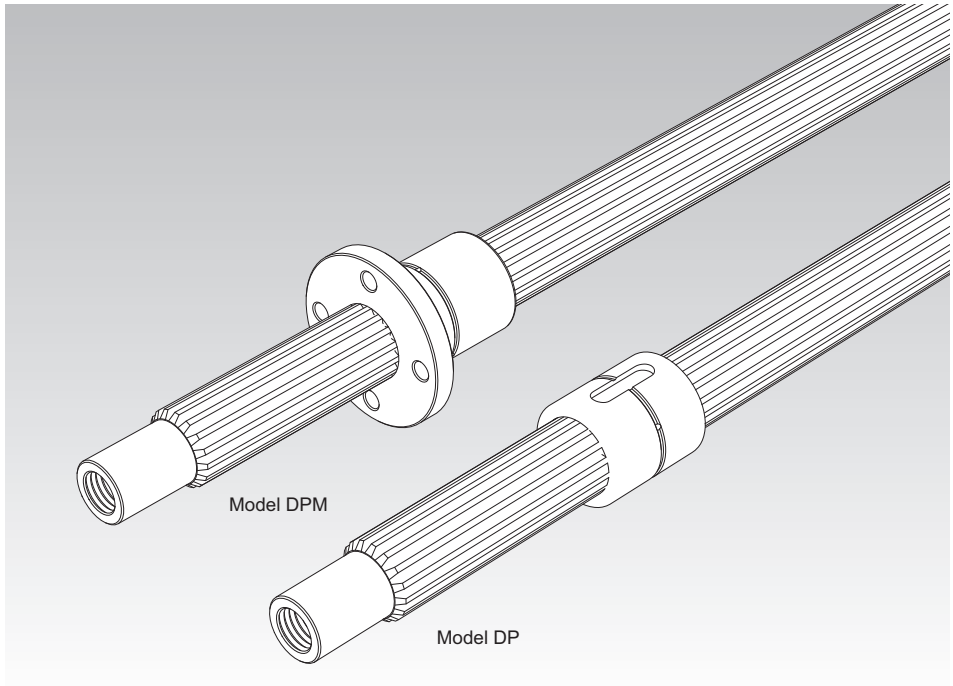

### Structure and Features

Spline Nut models DPM and DP are low price bearings that are made of a special alloy (see **B14-3**) formed by die casting and use highly accurate spline shafts as the core. Unlike conventional machined spline nuts, the sliding surface of these models maintains a chill layer formed in the rolling process, thus achieving high wear resistance.

The surface of the spline shafts to be used in combination with the nuts is hardened through rolling and is mirror-finished. Accordingly, smooth sliding motion is achieved.

The specially designed teeth of the spline have large contact areas, as well as concentricity, which enable the shaft to automatically establish the center as a torque is applied. Therefore, the teeth demonstrate stable performance in transmitting a torque.

## Features of the Special Rolled Shafts

Dedicated rolled shafts with standardized lengths are available for the Spline Nut.

### [Increased Wear Resistance]

The shaft teeth are formed by cold gear rolling, and the surface of the tooth surface is hardened to over 250 HV and mirror-finished. As a result, the shafts are highly wear resistant and achieve significantly smooth motion when used in combination with nuts.

### [Improved Mechanical Properties]

Inside the teeth of the rolled shaft, a fiber flow occurs along the contour of the tooth surface of the shaft, making the structure around the teeth roots dense. As a result, the fatigue strength is increased.

### [Additional Machining of the Shaft End Support]

Since each shaft is rolled, additional machining of the support bearing of the shaft end can easily be performed by lathing or milling.

## High Strength Zinc Alloy

The high strength zinc alloy used in the spline nuts is a material that is highly resistant to seizure and wear and has a high load carrying capacity. Information on mechanical properties, physical properties, and wear resistance is presented below.

\* The figures shown are target values—these figures are not guaranteed.

### [Mechanical Properties]

Table1

Item	Description
Tensile strength	275 to 314 N/mm <sup>2</sup>
Tensile yield strength (0.2%)	216 to 245 N/mm <sup>2</sup>
Compressive strength	539 to 686 N/mm <sup>2</sup>
Compressive yield strength (0.2%)	294 to 343 N/mm <sup>2</sup>
Fatigue strength	132 N/mm <sup>2</sup> × 10 <sup>7</sup> (Schenk bending test)
Charpy impact	0.098 to 0.49 N-m/mm <sup>2</sup>
Elongation	1 to 5 %
Hardness	120 to 145 HV

## [Physical Properties]

Table2

Item	Description
Specific gravity	6.8
Specific heat	460 J/ (kg•K)
Melting point	390 °C
Thermal expansion coefficient	$24 \times 10^{-6}$

## [Wear Resistance]

Table3 [Test conditions: Amsler wear-tester]

Item	Description
Test piece rotational speed	185 min <sup>-1</sup>
Load	392 N
Lubricant	Dynamo oil

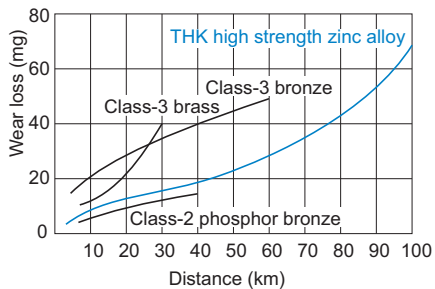

Fig.1 Wear Resistance of the High Strength Zinc Alloy

## Clearance in the Rotation Direction

Clearance in the rotational direction:  $\alpha \leq 20'$  MAX

## Selecting a Spline Nut

### [Dynamic Permissible Torque T]

The permissible dynamic torque (T) is the torque at which the contact surface pressure on the bearing tooth surface is  $9.8 \text{ N/mm}^2$ . These values are used as a reference for the strength of the spline nut.

### [pV Value]

With a sliding bearing, a pV value, which is the product of the contact surface pressure (p) and the sliding speed (V), is used as a measuring stick to judge whether the assumed model can be used. Use the corresponding pV value indicated in Fig.1 as a guide for selecting a spline nut. The pV value also varies according to the lubrication conditions.

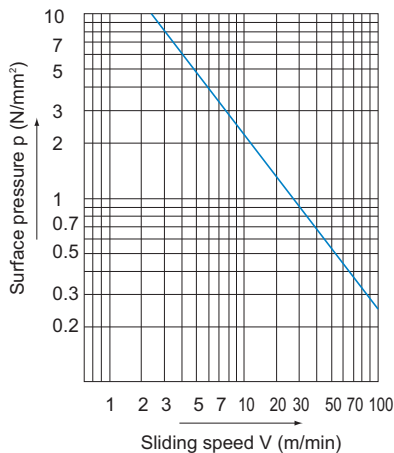

Fig.1 pV Value

Table1 Safety Factor ( $f_s$ )

Type of load	Lower limit of $f_s$
For a static load less frequently used	1 to 2
For an ordinary single-directional load	2 to 3
For a load accompanied by vibrations/impact	4 or greater

### ● $f_s$ : Safety Factor

To calculate a load applied to the spline nut, it is necessary to accurately obtain the effect of the inertia that changes with the weight and dynamic speed of an object. In general, with reciprocating or rotating machines, it is not easy to accurately obtain all the factors such as the effect of the start and stop, which are always repeated. Therefore, if the actual load cannot be obtained, it is necessary to select a bearing while taking into account the empirically obtained safety factors ( $f_s$ ) shown in Table1.

### ● $f_T$ : Temperature Factor

If the temperature of the spline nut exceeds the normal temperature range, the seizure resistance of the nut and the strength of the material will decrease. Therefore, it is necessary to multiply the dynamic permissible torque ( $T$ ) by the corresponding temperature factor indicated in Fig.2.

Accordingly, when selecting a spline nut, the following equations need to be met in terms of its strength.

Dynamic permissible torque ( $T$ )

$$f_s \leq \frac{f_T \cdot T}{P_T}$$

$f_s$  : Static safety factor

(see Table1 on [B14-5](#))

$f_T$  : Temperature factor (see Fig.2)

$T$  : Dynamic permissible torque (N-m)

$P_T$  : Applied torque (N-m)

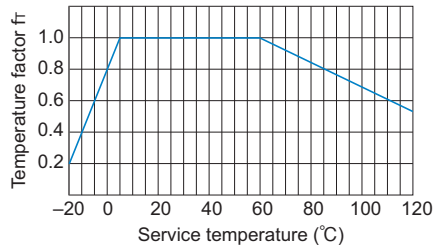

Fig.2 Temperature factor

### ● Hardness of the Surface and Wear Resistance

The hardness of the shaft significantly affects the wear resistance of the spline nut. If the hardness is equal to or less than 250 HV, the abrasion loss increases as indicated in Fig.3. The roughness of the surface should preferably be Ra0.80 or less.

A specially rolled shaft achieves surface hardness of 250 HV or greater, through hardening as a result of rolling, and a surface roughness of Ra0.20 or less. Thus, the dedicated rolled shaft is highly wear resistant.

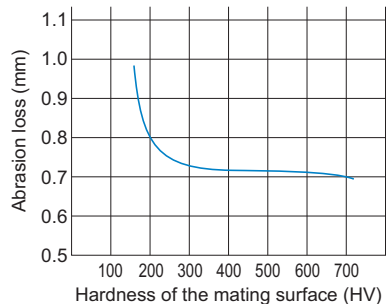

Fig.3 Hardness of the Surface and Wear Resistance

### [Calculating the Contact Surface Pressure $p$ ]

$$p = \frac{P_T}{T} \times 9.8$$

$p$  : Contact surface pressure on the tooth under a load torque ( $P_T$ ) (N/mm<sup>2</sup>)

$T$  : Dynamic permissible torque (N-m)

$P_T$  : Applied torque (N-m)

## Calculating the Sliding Speed V

With splines, the sliding speed of the tooth surface is equal to the feeding speed.

V : Sliding speed of the tooth (m/min)

### Example of calculation

Use Spline Nut DPM and reciprocate it at a speed in the axial direction of 5 m/min while transmitting a load torque of 78 N·m. Since the applied torque is not consistent in direction, it is important to select a spline nut that can be used in locations accompanied by vibrations and impact.

First, select a nut that has a dynamic permissible torque (T) at which it can be used.

$$T \geq \frac{f_s \cdot P_T}{f_T} = \frac{4 \times 78}{1} = 312 \text{ N} \cdot \text{m}$$

Safety factor ( $f_s$ ) = 4

Temperature factor ( $f_t$ ) = 1

Applied torque ( $P_T$ ) = 78 N·m

Select Spline Nut model DPM3560 (dynamic permissible torque T = 443 N·m), which satisfies the dynamic permissible torque (T) above.

Obtain the pV value.

Obtain the contact surface pressure (p).

$$p = \frac{P_T}{T} \times 9.8 = \frac{78}{443} \times 9.8 \doteq 1.73 \text{ N/mm}^2$$

Obtain the sliding speed (V).

$$V = 5 \text{ m/min}$$

From the diagram of pV values (see Fig.1 on **B 14-5**), it is judged that there will be no abnormal wear if the sliding speed (V) is 13.5 m/min or below against the "p" value of 1.73 N/mm<sup>2</sup>. Therefore, it is appropriate to select model DPM3560.

## Lubrication

Select a lubrication method according to the conditions of the spline nut.

### [Oil Lubrication]

For the lubrication of the spline nut, oil lubrication is recommended. Specifically, oil-bath lubrication or drop lubrication is particularly effective. Oil-bath lubrication is the most appropriate method since it meets harsh conditions such as high speed, heavy load or external heat transmission, and it cools the spline nut. Drop lubrication suits low to medium speed and a light to medium load. Select a lubricant according to the conditions as indicated in Table 1.

Table 1 Selection of a Lubricant

Condition	Types of Lubricants
Low speed, high load, high temperature	High-viscosity sliding surface oil or turbine oil
Low speed, light load, low temperature	Low-viscosity sliding surface oil or turbine oil

### [Grease Lubrication]

In low-speed feed, which occurs less frequently, the user can lubricate the slide system by manually applying grease to the shaft on a regular basis or using the greasing hole on the spline nut. We recommend using lithium-soap group grease No. 2.



## Model Number Coding

Model number configurations differ depending on the model features. Refer to the corresponding sample model number configuration.

### [Spline Nut]

#### ● Models DP, DPM and SS

- Spline Nut only

**DPM2040**

Model No. of spline nut

- Spline shaft only

**SS20 +1500L**

Overall spline shaft length (in mm)  
Model number of spline shaft

- Combination of spline nut and spline shaft

**2 DPM2040 +360L**

Overall spline shaft length (in mm)  
Model No. of spline nut  
Number of spline nuts used on the same shaft

## Notes on Ordering

If multiple spline nuts are to be mounted on a single shaft, please note that the locations of flange mounting holes and key grooves on the respective spline nuts may vary slightly. Avoid specifications that would require fitting multiple spline nuts to a single housing.

## Precautions on Use

## Spline Nut

### [Handling]

- (1) Tilting a spline nut or spline shaft may cause them to fall by their own weight.
- (2) Make sure the spline nut is not dropped or subjected to any sudden impact, as this could cause injury and damage the product. Even if there is no outward indication of damage, a sudden impact could prevent the unit from functioning properly.
- (3) When handling the product, wear protective gloves, safety shoes, etc., as necessary to ensure safety.

### [Precautions on Use]

- (1) Prevent foreign material, such as cutting chips or coolant, from entering the product. Failure to do so may cause damage.
- (2) If the product is used in an environment where cutting chips, coolant, corrosive solvents, water, etc., may enter the product, use bellows, covers, etc., to prevent them from entering the product.
- (3) If foreign material such as cutting chips adheres to the product, replenish the lubricant after cleaning the product.
- (4) Do not forcibly drive a pin, key, or other positioning device into this product; this could create indentations on the sliding surface and impair the product's function.
- (5) Skewing or misalignment of the spline shaft support and spline nut can shorten service life substantially. Inspect the components carefully and make sure they are mounted correctly.
- (6) Insufficient rigidity or accuracy of mounting members causes the bearing load to concentrate on one point and the bearing performance will drop significantly. Accordingly, give sufficient consideration to the rigidity/accuracy of the housing and base and strength of the fixing bolts.

### [Lubrication]

- (1) Thoroughly wipe off anti-rust oil and feed lubricant before using the product.
- (2) Do not mix different lubricants. Mixing greases using the same type of thickening agent may still cause adverse interaction between the two greases if they use different additives, etc.
- (3) When using the product in locations exposed to constant vibrations or in special environments such as clean rooms, vacuum and low/high temperature, use the grease appropriate for the specification/environment.
- (4) Following lubrication, perform several warm-up strokes with the unit to ensure that lubricant permeates the interior.
- (5) Lubricant viscosity can vary depending on the temperature. Please keep in mind that the spline nut's sliding resistance may be affected by changes in viscosity.
- (6) Following lubrication, stirring-resistance within the lubricant can cause the spline nut to exhibit increased sliding resistance. Before commencing operations, make sure to run the unit through several warm-up cycles to ensure that the lubricant is adequately integrated and dispersed.
- (7) Excess grease may scatter immediately after lubrication, so wipe off scattered grease as necessary.
- (8) The properties of grease deteriorate and its lubrication performance drops over time, so grease must be checked and added properly according to the use frequency of the machine.
- (9) The greasing interval varies depending on the use condition and service environment. Set the final lubrication interval/amount based on the actual machine.
- (10) If a lubricant will be used, the application must be designed in such a way that the spline nut's mounting position does not prevent lubricant from circulating.

## Precautions on Use

### [Storage]

Spline nuts should be stored horizontally in their original packaging in an indoor location where they are not exposed to abnormally high or low temperatures or high humidity.

### [Disposal]

Dispose of the product properly as industrial waste.

